

Bosch L-jetronic Fuel Injection Troubleshooting, Maintenance & Repair

Introduction:

[i - Table of Contents](#)

[ii - Table of Contents \(continued\)](#)

[iv - Introduction](#)

[v - Introduction \(continued\)](#)

Diagnosis: Starter runs, engine will not start:

[1 - Diagnostic process](#)

[2 - Air Intake System diagrams](#)

[3 - Diagnostic process \(continued\)](#)

[4 - Diagnostic process \(continued\)](#)

[5 - Diagnostic process \(continued\)](#)

[6 - Diagnostic process \(continued\)](#)

[7 - Diagnostic process \(continued\)](#)

[8 - Diagnostic process \(continued\)](#)

[9 - Diagnostic process \(continued\)](#)

[10 - Diagnostic process \(continued\)](#)

[11 - Diagnostic process \(continued\)](#)

[12 - Diagnostic process \(continued\)](#)

Diagnosis: Starter runs, engine will not start when cold:

[13 - Diagnostic process](#)

[14 - Diagnostic process \(continued\)](#)

Diagnosis: Starter runs, engine will not start when hot:

[15 - Diagnostic process](#)

[16 - Diagnostic process \(continued\)](#)

Diagnosis: Engine starts then stops:

[17/18 - Diagnostic process](#)

Diagnosis: Engine idles too high:

[19 - Diagnostic process](#)

[20 - Diagnostic process \(continued\)](#)

[21/22 - Diagnostic process \(continued\)](#)

Diagnosis: Engine idles too low, or rough idle:

[23/24 - Diagnostic process](#)

Diagnosis: Hesitation:

[25/26 - Diagnostic process](#)

Diagnosis: Inadequate power & poor performance:

[27 - Diagnostic process](#)

[28 - Diagnostic process \(continued\)](#)

Diagnosis: Excessive fuel consumption:

[29/30 - Diagnostic process](#)

Diagnosis: CO value too high:

[31 - Diagnostic process](#)

Electrical diagrams:

[32 - Electrical component location](#)

[33 - Check coolant temperature sensor resistance](#)

[34 - Check thermo time switch](#)

[35 - Check air flow meter](#)

[36 - Check air flow meter \(continued\)](#)

[37 - Check air flow meter \(continued\)](#)

[38 - Check voltage output to fuel pump @ relay set](#)

[39 - Check voltage input to relay set from ignition switch](#)

[40 - Check voltage input to fuel pump relay of relay set](#)

[41 - Check input voltage to control relay of relay set](#)

[42 - Check input voltage to control relay of relay set \(continued\)](#)

[43 - Check output voltage from control relay of relay set](#)

[44 - Check output voltage from control relay of relay set \(continued\)](#)

[45 - Check output voltage from control relay of relay set \(continued\)](#)

[46 - Check voltage signal from coil to control unit](#)

[47 - Check ground circuit for control unit](#)

[48 - Check ground circuit for control unit \(continued\)](#)

[49 - Check ground circuit for control unit \(continued\)](#)

[50 - Check air temperature sensor resistance](#)

- [51 - Check input to fuel pump relay of relay set](#)
- [52 - Check voltage @ auxiliary air regulator](#)
- [53/54 - Check full throttle contacts of throttle plate switch](#)

FI Maintenance: 1500cc engine:

- [55 - Maintenance process](#)
- [56 - Maintenance process \(continued\)](#)
- [57 - Maintenance process \(continued\)](#)
- [58 - Maintenance process \(continued\)](#)
- [59 - Maintenance process \(continued\)](#)
- [60 - Maintenance process \(continued\)](#)
- [61 - Maintenance process \(continued\)](#)
- [62 - Maintenance process \(continued\)](#)
- [63 - Maintenance process \(continued\)](#)
- [64 - Maintenance process \(continued\)](#)

FI Maintenance: 2000cc engine:

- [65 - Maintenance process](#)
- [66 - Maintenance process \(continued\)](#)
- [67 - Maintenance process \(continued\)](#)
- [68 - Maintenance process \(continued\)](#)
- [69 - Maintenance process \(continued\)](#)
- [70 - Maintenance process \(continued\)](#)
- [71 - Maintenance process \(continued\)](#)
- [72 - Maintenance process \(continued\)](#)

Appendix: FI electrical system:

- [73/74 - Electrical system diagram](#)
- [75 - Test specs](#)
- [76 - Test specs \(continued\)](#)

TABLE OF CONTENTS

	Page
Introduction	
How To Use This Book	iv
Diagnosis	
Starter runs, engine will not start	1
Starter runs, engine will not start when cold	13
Starter runs, engine will not start when hot	15
Engine starts then stops	17
Engine idles too high	19
Low idle speed or rough idle	23
Hesitation	25
Inadequate power or poor performance	27
Excessive fuel consumption	29
CO value too high	31
Electrical Diagrams	
Electrical component location	32
Check coolant temperature sensor resistance	33
Check thermo time switch	34
Check air flow sensor	35
Check air flow sensor	36
Check air flow sensor	37
Check voltage output to fuel pump at relay set	38
Check voltage input to relay set from ignition switch	39
Check voltage input to fuel pump relay of relay set	40
Check input voltage to control relay of relay set	41
Check input voltage to control relay of relay set	42
Check output voltage from control relay of relay set	43
Check output voltage from control relay of relay set	44
Check output voltage from control relay of relay set	45
Check voltage signal from coil to control unit	46
Check ground circuit for control unit	47
Check ground circuit for control unit	48
Check ground circuit for control unit	49
Check air temperature sensor resistance	50
Check input to fuel pump relay of relay set	51
Check voltage at auxiliary air regulator	52
Check full throttle contacts of throttle plate switch	53
Maintenance — 1500 cc engine	
Air cleaner filter replacement	55
Idle speed adjustment	55
Accelerator linkage stop screw adjustment	55
Idle CO adjustment	56
Accelerator and kickdown cable adjustment	57
Throttle plate switch adjustment	58
Lambda sensor indicator reset	58
Lambda sensor replacement	59

Fuel injectors removal and installation	59
Fuel pressure regulator removal and installation	63
Cold start valve removal and installation	63
Air flow sensor removal and installation	64
Auxiliary air regulator removal and installation	64
Throttle plate switch removal and installation	64
Maintenance – 2000 cc engine	
Air cleaner filter replacement	65
Idle speed adjustment	65
Accelerator linkage stop screw adjustment	65
Idle CO adjustment	66
Accelerator and kick-down cable adjustment	67
Throttle plate switch adjustment	68
Lambda sensor indicator reset	68
Lambda sensor replacement	69
Fuel injectors removal and installation	69
Fuel pressure regulator removal and installation	71
Cold start valve removal and installation	71
Air flow sensor removal and installation	72
Auxiliary air regulator removal and installation	72
Throttle plate switch removal and installation	72
Appendix	
Electrical system	73

INTRODUCTION

How to Use This Book

This book provides illustrated step-by-step diagnostic procedures for various trouble symptoms. Experience with fuel injection systems has shown that most troubles attributed to the system are really troubles with other systems, such as ignition, engine, electrical, etc. Therefore before troubleshooting the fuel injection system you should road test the car and then check the following:

- condition of battery
- condition of spark plugs
- ignition timing
- valve timing
- engine compression
- idle speed

Whenever it is possible an HC-CO test should be performed using an infrared analyzer. The test results can be a valuable aid to proper diagnosis of the fuel injection system.

The procedure for connecting the analyzer and making the test is given in the maintenance section.

After you have confirmed that these are correct, find the symptom which best describes the condition. Follow the procedures in this book to isolate the problem.

Throughout the book you will see "If test light does not light check wires indicated in diagram. If wires are good, replace component." The wires to be checked on the diagram are indicated by heavier lines. To check the wires use an ohmmeter and check for continuity from pin to pin.

The electrical system can be checked using only an ohmmeter and a test light. A voltmeter can be used instead of a test light to obtain specific readings. When connecting test equipment make sure you are on the correct terminal and not touching any other wire. Make sure you have a good ground point when required.

The symbols used for the test equipment are:

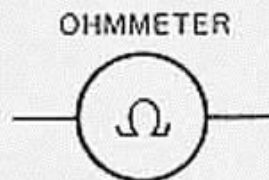
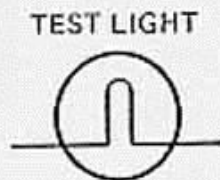

Whenever it is necessary to open the fuel system you will see

WARNING: FIRE HAZARD

Before opening the system, relieve fuel pressure as follows:

- Remove fuel tank cap.
- Disconnect vacuum hose from fuel pressure regulator.
- Using a hand vacuum pump, apply about 25 in. Hg to the pressure regulator.

NOTE: Fuel pressure will be released into the fuel tank through the fuel return hose.

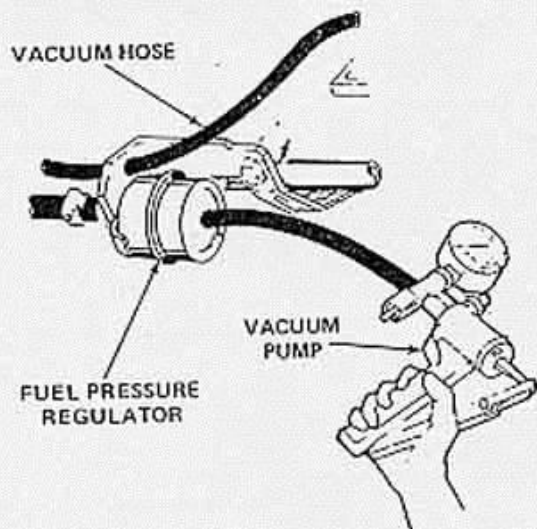

Use care when working with an open fuel system. Do not Smoke. Keep any open flame away. Make sure fuel does not come in contact with skin, eyes or hot surfaces such as exhaust manifolds. Be careful of sparks from battery or ignition system. A work area with adequate ventilation should be used.

The fuel injection system is highly susceptible to contamination. Make sure the area is clean whenever you remove either the cold start valve or injectors or disconnect a fuel hose. Use extreme care so that no dirt enters the fuel system.

A fuel injection system electrical diagram is included at the end of the manual to assist you in component identification and system diagnosis. The page should be folded out for reference while using the manual.

DIAGNOSIS

Page 1

STARTER RUNS, ENGINE WILL NOT START

NOTE: Disconnect electrical connector from thermo-time switch to prevent it from heating up during the following checks.

1. Check Ignition System

Disconnect a spark plug cable and check for spark. If spark is not sufficient, check electronic ignition system. Use an oscilloscope.

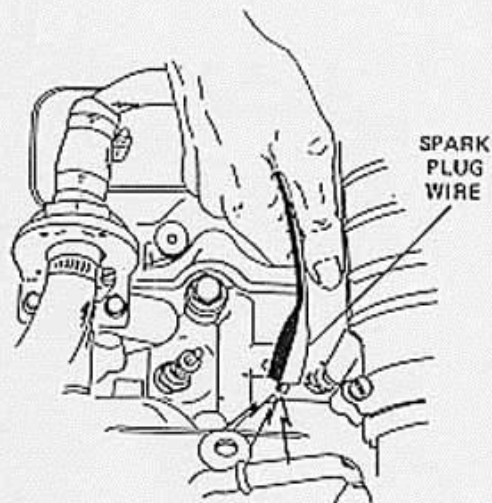

2. Check Intake Air System

Check all air lines for leaks or damage. Repair leaks or replace lines. See diagrams on next page.

3. Check Fuel Feed Pressure

WARNING: FIRE HAZARD

Relieve fuel system pressure.
Disconnect fuel line from cold start valve.
CAUTION: Use care in pulling fuel line off valve. Valve body is plastic.

Connect pressure gauge to fuel line and cold start valve. Secure hose with clamp.

Disconnect vacuum line from fuel pressure regulator. Operate starter or with ignition switch on, deflect air flow sensor flap and check pressure reading.

FUEL FEED PRESSURE – 36 ± 3 psi

NOTE: Pressure should build up rapidly and hold after the ignition switch is turned off.

When applicable, let engine idle. Connect vacuum hose to pressure regulator and check pressure reading.

FUEL FEED PRESSURE – approx. 28 psi

a. If pressure is correct, go to check 4.

WARNING: FIRE HAZARD

b. If pressure is over specifications, relieve system pressure. Disconnect fuel return hose from regulator. Connect test hose to regulator. Place test hose in a container. Crank engine and check gauge. Remove test hose and reconnect return hose.

1. If pressure is still over specifications, replace regulator.

2. If pressure drops to specifications, inspect return line for damage or blockage.

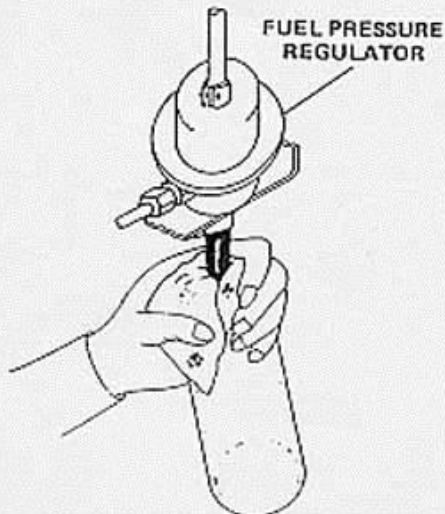
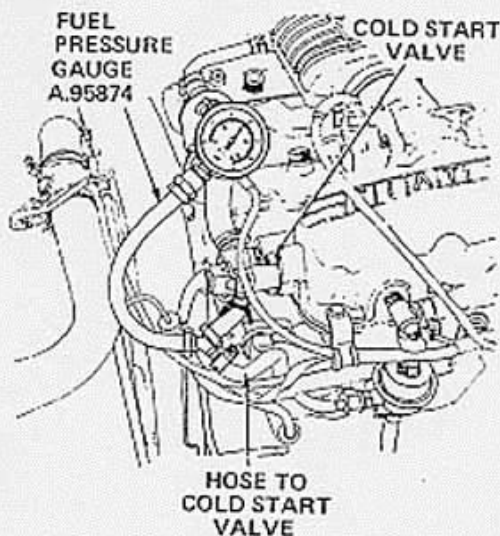

AIR INTAKE SYSTEM

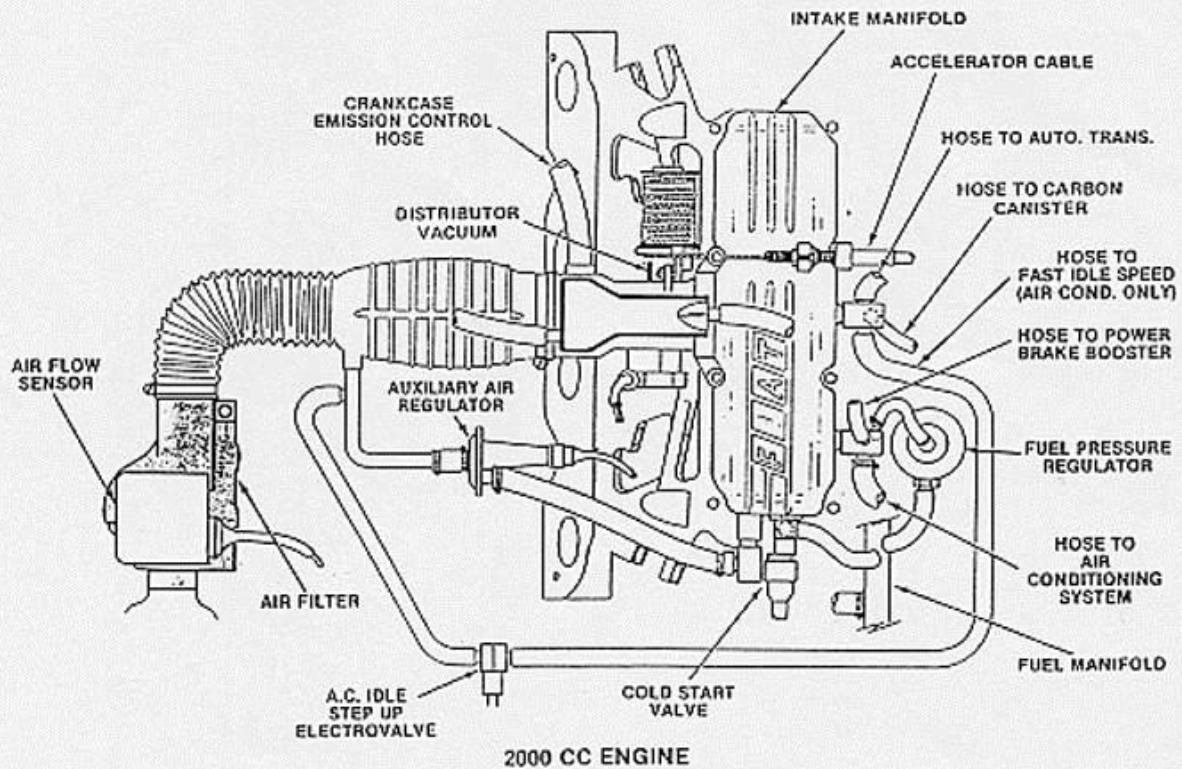
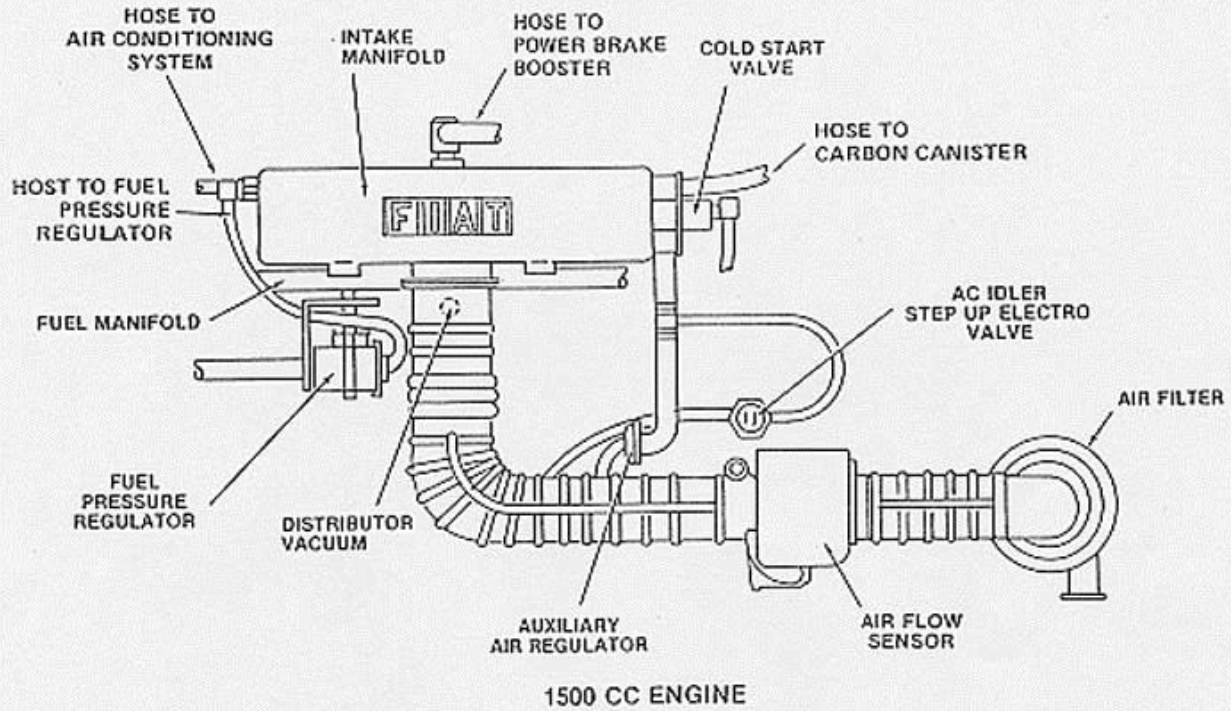

DIAGNOSIS

Page 3

STARTER RUNS, ENGINE WILL NOT START *(continued)*

c. If pressure is under specifications, slowly pinch the return fuel line. Use pinch-off pliers to prevent damage to the hose.

CAUTION: Do not allow pressure to exceed 60 psi.

1. If pressure increases, replace regulator.
2. If pressure remains constant, inspect feed line and filter for blockage and damage. If feed line and filter are good, replace pump.

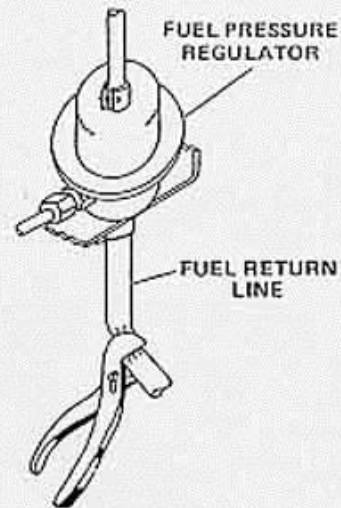

d. If gauge shows no pressure, check if fuel pump is running.

1. If fuel pump is not running, go to test 9.
2. If fuel pump is running, inspect fuel feed line for blockage or damage. If fuel feed line is OK, replace fuel pump.

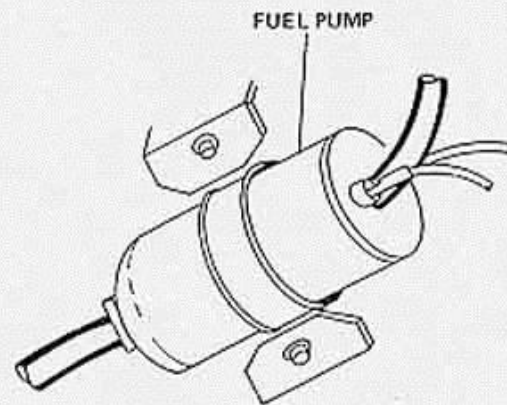

4. Check Voltage at Injectors

Disconnect electrical connector from one injector. Connect a test light between the terminals in the connector.

Operate starter motor and check test light.

The test light should come on with weak and flickering intensity.

- a. If test light comes on with weak and flickering intensity, go to check 5.
- b. If test light does not come on, go to check 13.
- c. If test light is always on, replace electronic control unit.

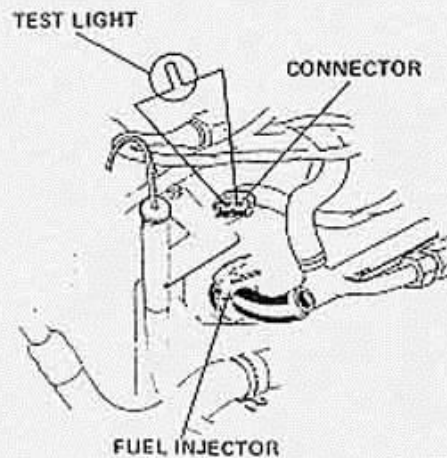

5. Check Coolant Temperature Sensor Resistance

Turn ignition switch off. Disconnect connector from electronic control unit. Connect an ohmmeter between terminals 13 of the connector and ground. See diagram 1, page 33.

Check ohmmeter reading. Meter should read:

OHMS	COOLANT TEMPERATURE
7,000 to 12,000	-10°C (14°F)
2,000 to 3,000	20°C (68°F)
250 to 400	80°C (176°F)

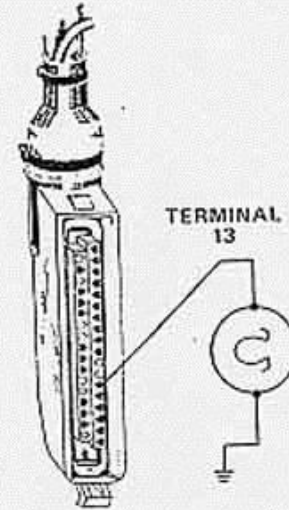

- If reading is good, go to check 6.
- If reading is 0 ohms or less than specified, replace sensor.
- If reading is ∞ (infinity), check the wires indicated in diagram 1 for breaks. If wires are good, replace sensor.

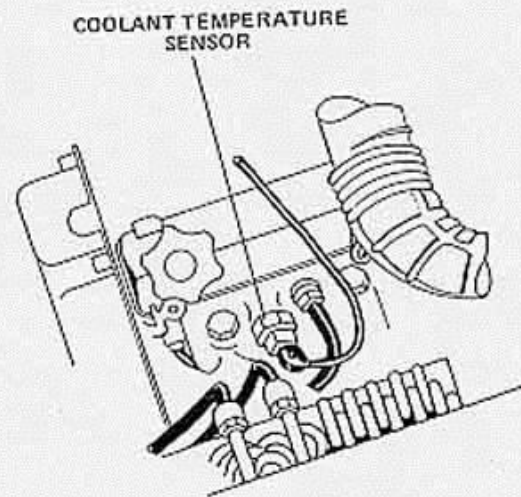

6. Check Thermo Time Switch

Connect electrical connector to thermo-time switch. Disconnect connector from cold start valve. Connect test light between terminals in connector. Operate starter and check time that test light is lit. Test light should be on for

TIME	COOLANT TEMPERATURE
1 to 8 seconds	Lower than 35°C (95°F)
No light	Above 35°C (95°F)

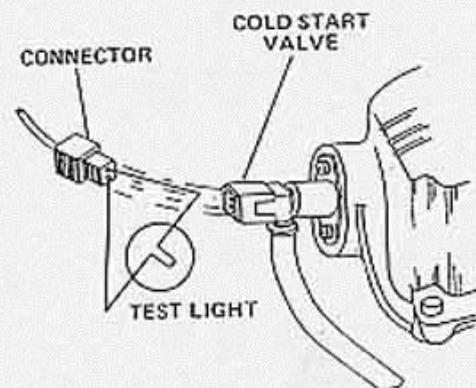

STARTER RUNS, ENGINE WILL NOT START (continued)

- a. Test light stays on correctly, go to check 7.
- b. Test light stays on over 8 seconds, replace thermo time switch.
- c. See diagram 2, page 34. Test light does not come on with coolant temperature below 35°C, connect test light between terminal 86 of relay set and ground. Crank engine.
 1. If light does not come on, check wires indicated in diagram 2 for breaks. If wires are good, replace thermo-time switch.
 2. If light comes on, connect test light between terminal 86a of relay set and ground. Crank engine.
 - If light comes on, replace relay set.
 - If light does not come on, check wire from terminal 86a to starter or ignition switch.

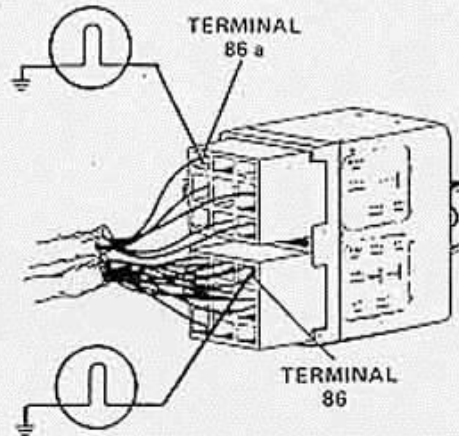

7. Check Cold Start Valve

WARNING: FIRE HAZARD

Relieve fuel system pressure. Remove the two bolts holding the cold start valve in the intake manifold. Do not disconnect fuel line or electrical connector. Place cold start valve in a container to catch injected fuel.

Disconnect electrical connector from thermo-time switch. Jumper wire to terminal 46 of switch to ground.

Operate starter and check valve for spray. Valve should spray.

Disconnect jumper from thermo-time switch connector. Valve should close and there should not be any spray or drips.

Connect electrical connector to thermo-time switch.

- a. Valve sprays fuel correctly, install cold start valve and go to check 8.
- b. Valve sprays continuously or drips, replace valve.
- c. Valve does not spray, replace valve.

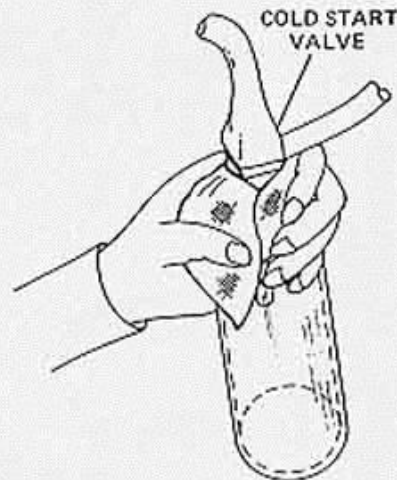
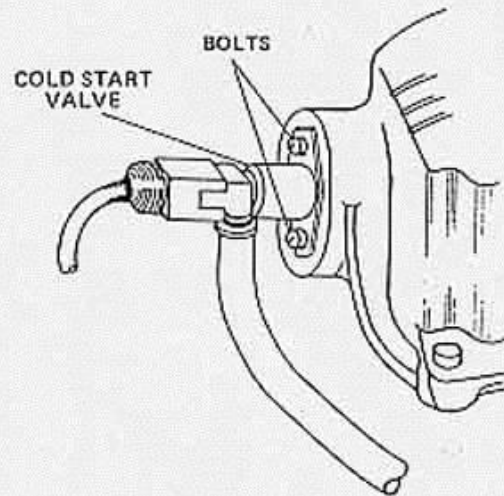

8. Check Air Flow Sensor

Remove the air flow sensor or hose. Check the sensor plate by hand for free movement. Check that plate closes against stop when released.

NOTE: Make sure sensor is clean on inside. If necessary, clean only with a dry cloth.

- a. If sensor plate does not move freely or return to closed position, replace air flow sensor.

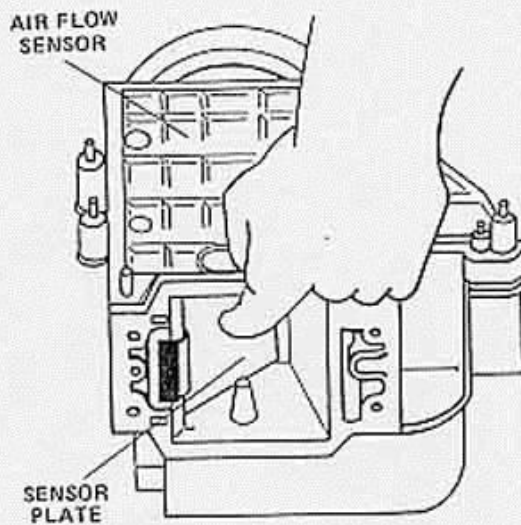

- b. If sensor plate operates properly, turn ignition switch off. Disconnect connector from electronic control unit. Perform steps 1 thru 3 below.

1. Connect ohmmeter between terminals 6 and 8 of connector. See diagram 3, page 35.

Resistance should be no more than 600 ohms

- a. If resistance is correct, go to step 2 below.

- b. If resistance is not correct, check wires indicated in diagram 3. If wires are good, replace air flow sensor.

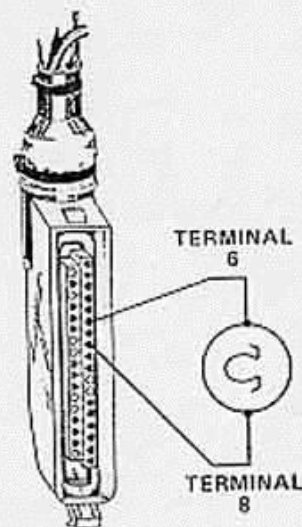

2. Connect ohmmeter between terminals 7 and 8 of connector. See diagram 4, page 36.

Resistance should be no more than 1200 ohms

- a. If resistance is correct, go to step 3 below.

- b. If resistance is not correct, check wires indicated in diagram 4. If wires are good, replace air flow sensor.

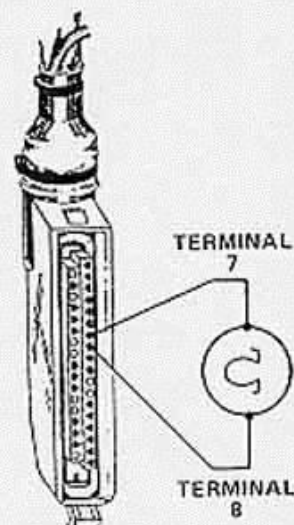

STARTER RUNS, ENGINE WILL NOT START (continued)

3. Connect ohmmeter between terminals 8 and 9 of connector. See diagram 5, page 37.

Resistance should be no more than 350 ohms

- a. If resistance is correct in all 3 steps, the problem is not in the fuel injection system.
- b. If resistance is not correct, check wires indicated in diagram 5. If wires are good, replace air flow sensor.

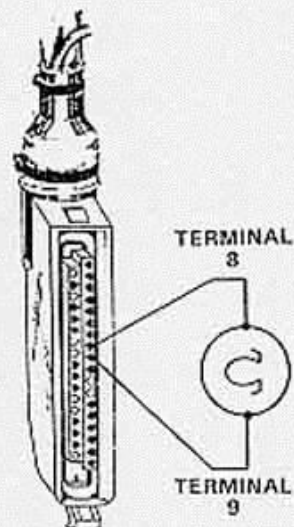

9. Check for Voltage at Fuel Pump

Disconnect 2 wires from Fuel pump. Connect test light between wires. Operate starter and check test light.

Test light should come on.

- a. If test light does not come on, go to check 10.
- b. If test light comes on, replace pump.

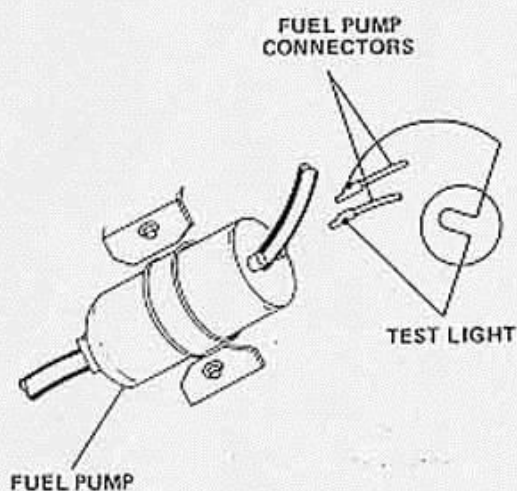

10. Check for Voltage Output to Fuel Pump at Relay Set

Connect a test light between terminal 88d of the relay set connector and a good ground. Operate the starter and check test light. See diagram 6, page 38.

Test light should light.

- a. If test light does not come on, go to check 11.
- b. If test light comes on, check wire from double relay to fuel pump and wire from pump to ground.

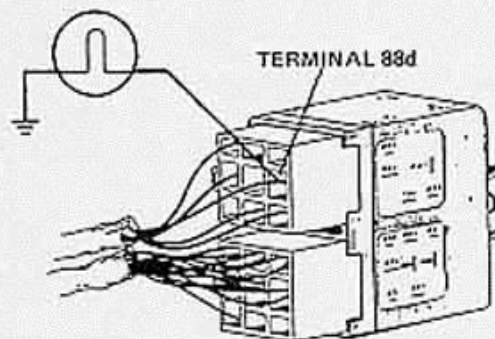

11. Check Voltage Input to Relay Set from Ignition Switch

Connect test light between terminals 86a and 85 of relay set connectors. See diagram 7, page 39.

Operate starter and check test light.

a. If test light comes on, go to check 12.

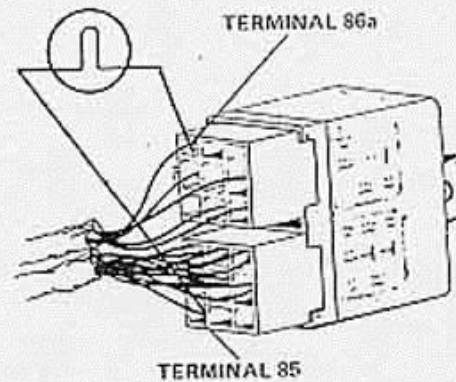

b. If test light does not come on, connect test light between terminal 86a and a good ground. Operate starter and check test light.

1. If test light does not come on, check wiring from double relay to ignition switch.

2. If test light comes on, check wiring indicated in diagram 7 for breaks. If wiring is good, replace control unit.

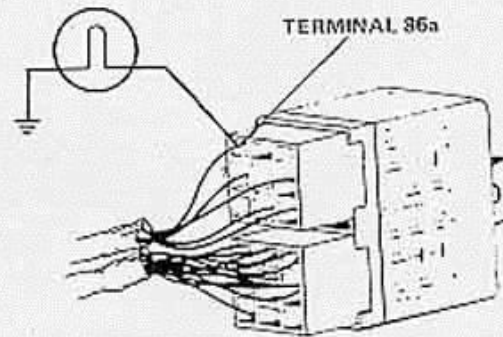

12. Check Voltage Input to Fuel Pump Relay of Relay Set

Connect test light between terminals 88y and 85 of relay set connectors. See diagram 8, page 40. Turn ignition switch on.

Test light should come on.

a. If test light comes on, replace double relay.

b. If test light does not come on, check fuse and wiring to double relay connectors.

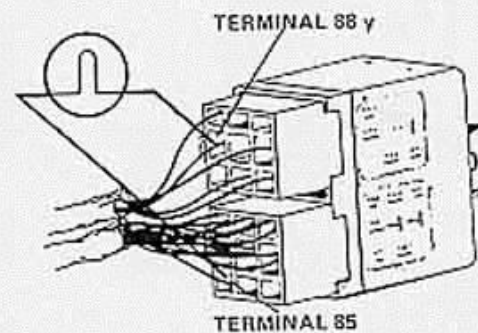

STARTER RUNS, ENGINE WILL NOT START (continued)

13. Check Input Voltage to Control Relay of Relay Set

- Connect test light between terminals 88z and 85 of relay set connectors. See diagram 9, page 41. Test light should come on.
- a. If test light comes on, go to check 14.

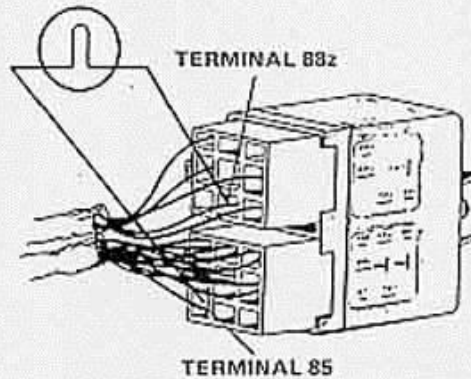

- b. If test light does not come on, connect test light between terminal 88z and ground.
 1. If test light does not come on, check wiring between double relay and ground.
 2. If test light comes on, check wiring indicated in diagram 9 for breaks. If wiring is good, replace control unit.

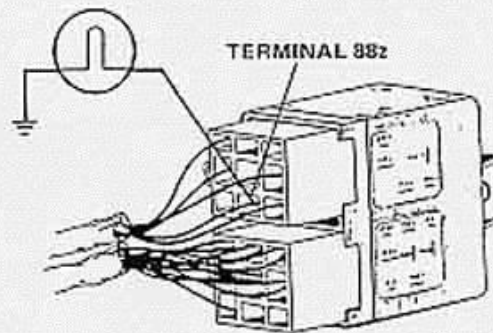

14. Check Input Voltage to Control Relay of Relay Set

- Connect test light between terminals 86c and 85 of relay set connectors. See diagram 10, page 42. Turn ignition switch on. Test light should come on.
- a. If test light comes on, go to check 15.
 - b. If test light does not come on, check wiring between double relay and ignition switch.

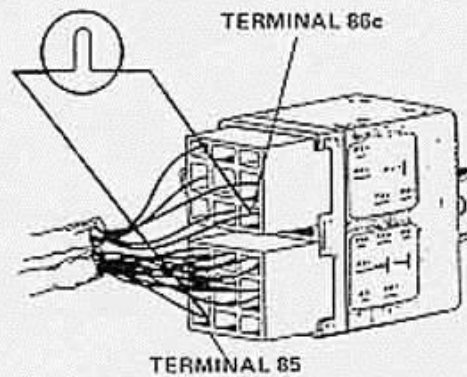

15. Check Output Voltage from Control Relay of Relay Set

Connect test light between terminals 88a and 85 of relay set connectors. See diagram 11, page 43. Turn ignition switch on.

- a. If test light comes on, go to check 16.
- b. If test light does not come on, replace double relay.

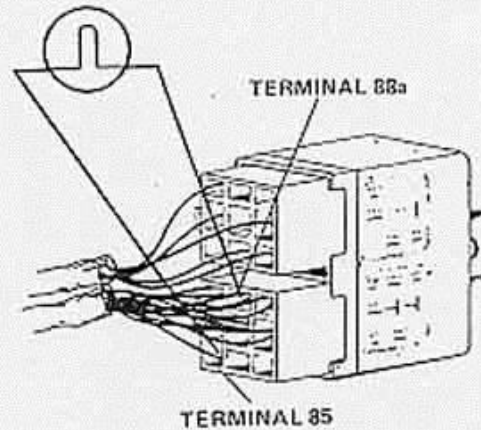

16. Check Output Voltage from Control Relay of Relay Set

Connect test light between terminals 88e and 85 of relay set connectors. See diagram 12, page 44. Turn ignition switch on.

- a. If test light comes on, go to check 17.
- b. If test light does not come on, replace double relay.

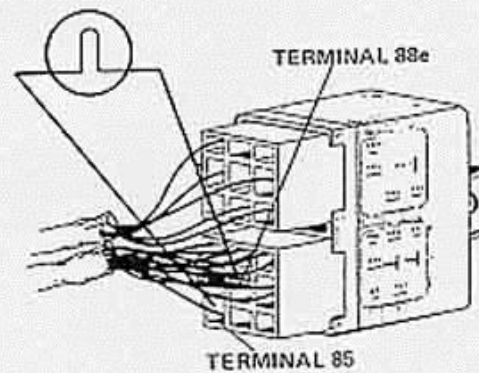

17. Check Output Voltage from Control Relay of Relay Set

Connect test light between terminals 88b and 85 of relay set connectors. See diagram 13, page 45. Turn ignition switch on.

- a. If test light comes on, go to check 18.
- b. If test light does not come on, replace double relay.

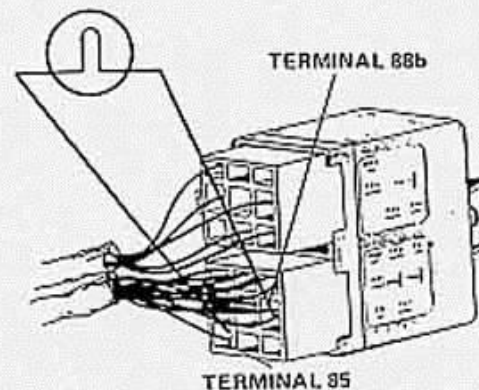

STARTER RUNS, ENGINE WILL NOT START *(continued)*

18. Check Voltage Signal from Coil to Electronic Control Unit

On all models, disconnect connector from control unit. Connect test light between terminal 1 of control unit connector and ground. See diagram 14, page 46. Operate starter and check test light.

Test light should come on with flickering intensity.

- a. If test light comes on with flickering intensity, go to check 19.
- b. If test light does not come on, check wiring indicated in drawing 14 for breaks.

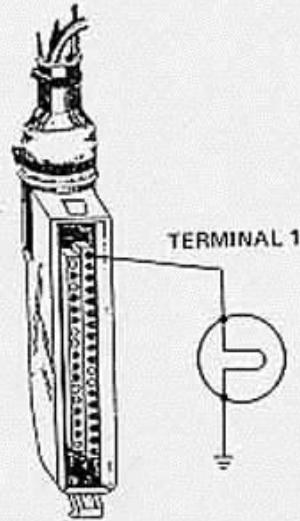

19. Check Ground Circuit for Control Unit

On 2000 cc engine, disconnect connector from control unit. Connect test light between terminals 1 and 5 of control unit connector. See diagram 15, page 47. Turn ignition switch on.

Test light should come on.

- a. If test light does not come on, check wiring indicated in diagram 15 for breaks.

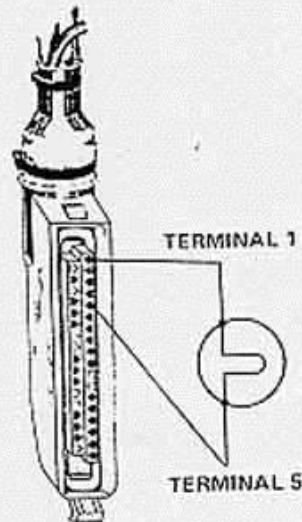

- b. If test light comes on, connect test light between terminals 1 and 16. See diagram 16, page 48.

Test light should come on.

- c. If test light does not come on, check wiring indicated in diagram 16 for breaks.

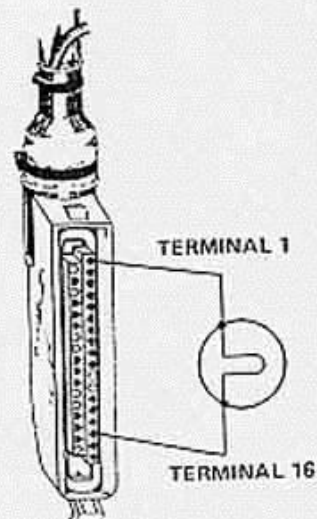

- d. If test light comes on, connect test light between terminals 1 and 17. See diagram 17, page 49. Test light should come on.
- e. If test light comes on, replace control unit.
- f. If test light does not come on, check wiring indicated in diagram 17 for breaks.

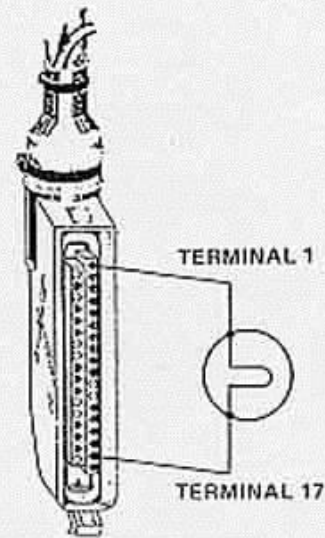

On 1500 cc engine, turn ignition switch off and use an ohmmeter in place of the test light specified for 2000 cc engine. Connect ohmmeter to terminals 5, 16 and 17 in sequence and to a known good ground. The ohmmeter should indicate 0 ohms in all three steps.

- a. If ohmmeter indicates 0 ohms in all three steps, replace control unit.
- b. If ohmmeter does not indicate 0 ohms, check wiring indicated in diagrams 15, 16 or 17 for breaks.

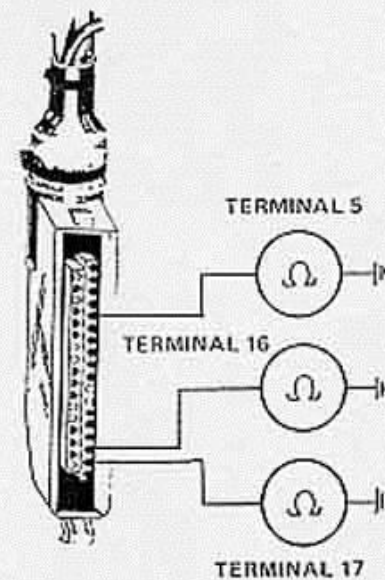

STARTER RUNS, ENGINE WILL NOT START WHEN COLD

20. Make the checks listed below in the order listed.

1. Check ignition system, check 1, page 1.

WARNING: FIRE HAZARD

2. Relieve fuel system pressure. Remove two bolts holding cold start valve in intake manifold. Do not disconnect fuel line. Place cold start valve in container to catch injected fuel.

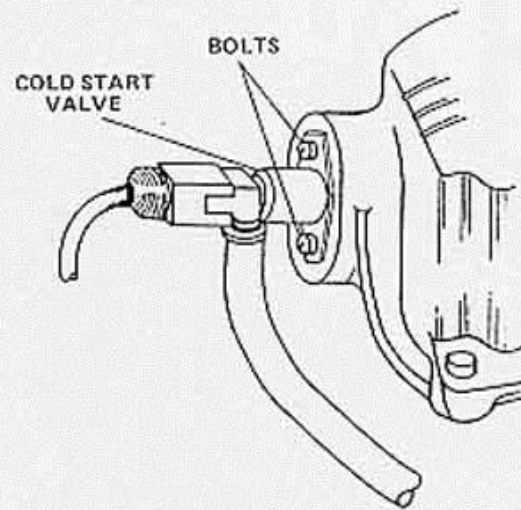

Disconnect electrical connector from thermo-time switch. Jumper wire in connector for terminal 46 of switch to ground.

Operate starter and check valve for spray. Valve should spray.

- a. If valve sprays, go to step 3.

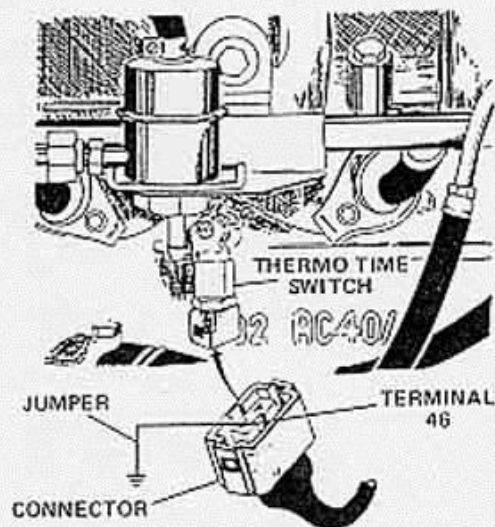

- b. If valve does not spray, connect test light to terminal 45 of cold start valve and ground. Operate starter.

- If test light comes on, replace cold start valve.

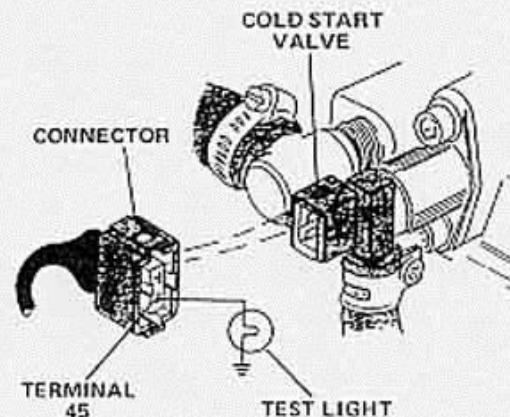

- If test light does not come on, connect test light to terminal 86 of double relay and ground. Operate starter.
- If test light comes on, repair wire #47 from relay terminal 86 to cold start valve.
- If test light does not come on, connect test light to terminal 86a of double relay and ground. Operate starter.
 - If test light comes on, replace relay.
 - If test light does not come on, check wire from terminal 86a to starter or ignition switch.

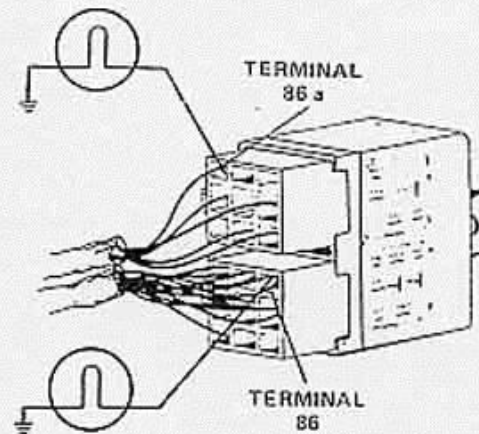

3. Connect electrical connector to thermo-time switch. Operate starter. Check cold start valve for spray.

Valve should spray fuel for

TIME	COOLANT TEMPERATURE
1 to 8 seconds	Lower than 35° C (95° F)
No spray or drip	Above 35° C (95° F)

a. Valve sprays fuel correctly, install cold start valve and perform remaining checks of STARTER RUNS, ENGINE WILL NOT START.

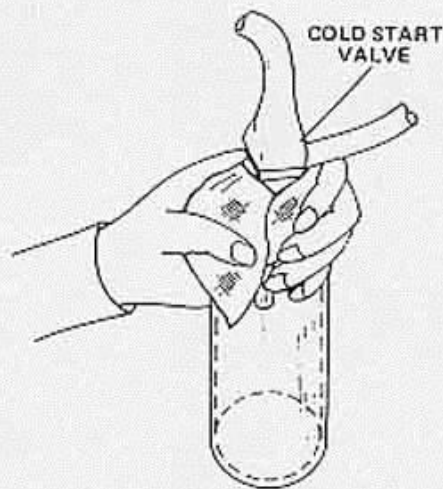

b. Valve does not spray, connect test light to terminal 45 in connector for thermo-time switch. Operate starter.

Test light should come on.

- Test light comes on, replace thermo-time switch.
- Test light does not come on, repair wire from thermo-time switch to cold start valve.

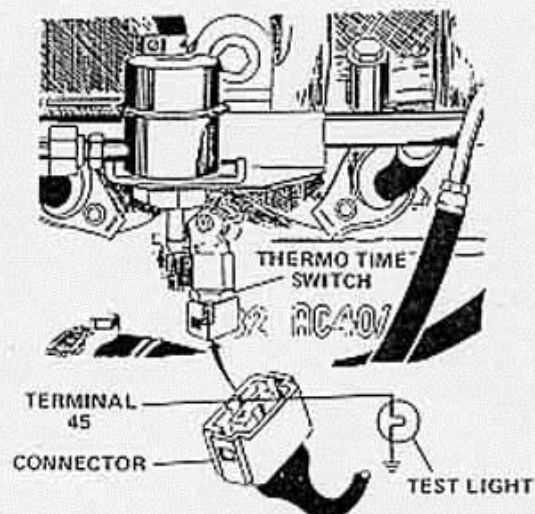

STARTER RUNS, ENGINE WILL NOT START WHEN HOT

21. Make the checks listed below in the order listed.

1. Check ignition system, check 1, page 1.
2. Check fuel feed pressure, check 3, page 1.
3. Check coolant temperature sensor, check 5, page 4.
4. Disconnect electrical connector from cold start valve. Connect ohmmeter to wire in connector for terminal 46 and ground. Check ohmmeter reading.
 - a. If meter reads open, go to step 5.
 - b. If meter reads 0 ohms, check wire from cold start valve to thermo-time switch for short to ground. If wire is good, replace thermo-time switch.

WARNING: FIRE HAZARD

5. Relieve fuel system pressure. Remove two bolts holding cold start valve in intake manifold. Do not disconnect fuel line. Place cold start valve in a container to catch injected fuel.

Operate starter and check valve. Valve should not spray or drip fuel.

- a. If valve is good, go to check 22.
- b. If valve sprays or drips, replace valve.

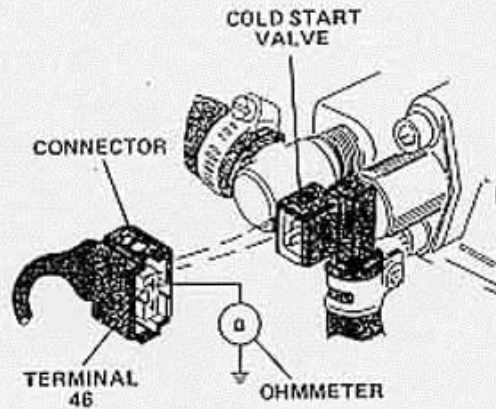

22. Check Injectors for Leaks

WARNING: FIRE HAZARD

Relieve fuel system pressure. Remove injectors from intake manifold. Position injectors in containers to catch fuel. Disconnect wire from terminal 1D of coil. Operate starter and check injectors.

Maximum leakage is 2 drops per minute per injector.

- a. If injectors do not leak, go to check 23.
- b. If any injector leaks excessively, replace it.

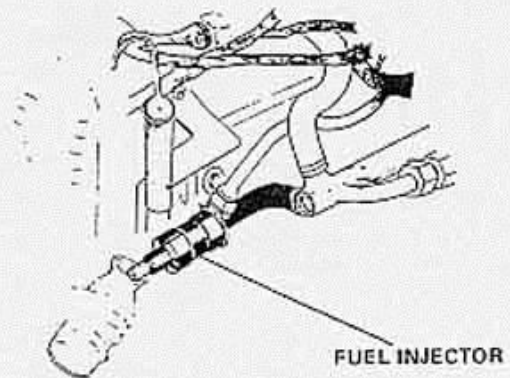

23. Check Air Temperature Sensor Resistance

Turn ignition switch off. Disconnect connector from control unit. Connect ohmmeter between terminals 6 and 27. See diagram 18, page 50.

INTAKE AIR TEMPERATURE	RESISTANCE (OHMS)
-10°C (14°F)	7,000 to 12,000
20°C (68°F)	2,000 to 3,000
50°C (122°F)	250 to 400

- If resistance is correct, perform remaining checks under STARTER RUNS, ENGINE WILL NOT START.
- If resistance is 0 or other than specified, replace air flow sensor.
- If resistance is infinity, check wires indicated in diagram 18. If wires are good, replace air flow sensor.

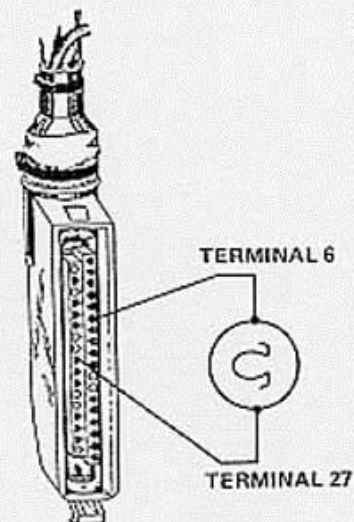

ENGINE STARTS THEN STOPS

24. Check Output to Fuel Pump from Fuel Pump Relay of Relay Set

Disconnect hose to air flow sensor. Connect test light to terminal 88d of relay set and ground. See diagram 19, page 51. Turn ignition switch on. Move sensor flap and check test light.

With sensor flap closed, test light should be off. With sensor flap open, test light should come on.

- a. If test light operates properly, go to check 26.
- b. If test light does not operate properly, go to check 25.

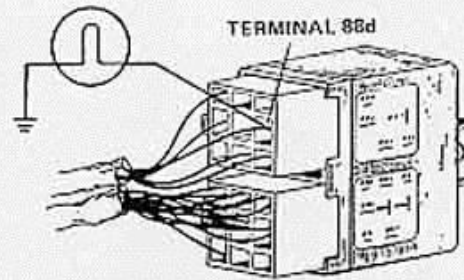

25. Check Input to Fuel Pump Relay of Relay Set

Connect test light to terminal 86b of relay set and ground. See diagram 19, page 51. Move sensor flap and check test light. With sensor flap closed, test light should be off. With sensor flap open, test light should come on.

- a. If test light operates properly, replace relay set.
- b. If test light does not operate properly check wires indicated in diagram 19. If wires are good, replace air flow sensor.

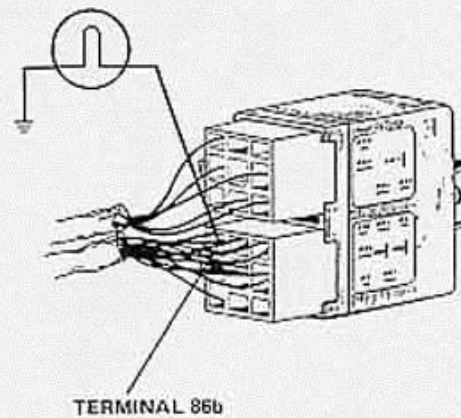

26. Check Cold Start Valve

Pinch off the fuel feed line to the cold start valve. Use pinch-off pliers to prevent damage to the hose. Start engine.

The engine should start and run.

- a. If engine starts and runs, perform check 7, page 5.
- b. If engine starts and then stops, perform check 2, page 1, and check 5, page 4. If these checks are OK, perform remaining checks under STARTER RUNS, ENGINE WILL NOT START.

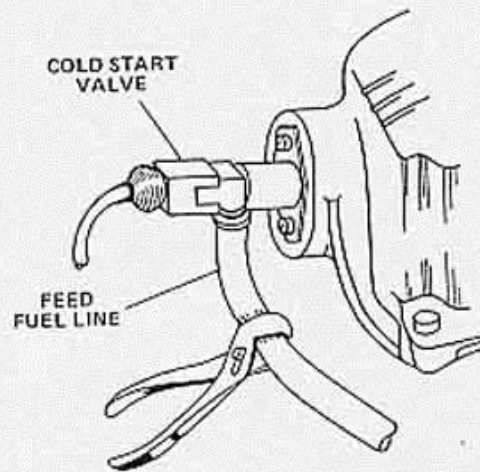

ENGINE IDLES TOO HIGH

27. Check Idle Speed Adjustment

With engine at normal running temperature, turn in idle adjustment screw all the way. Turn accelerator linkage stop screw out all the way. Engine idle speed should drop and engine may stall.

- a. If idle speed does not change, go to check 28.
- b. If idle speed drops, adjust engine idle speed, see maintenance section.

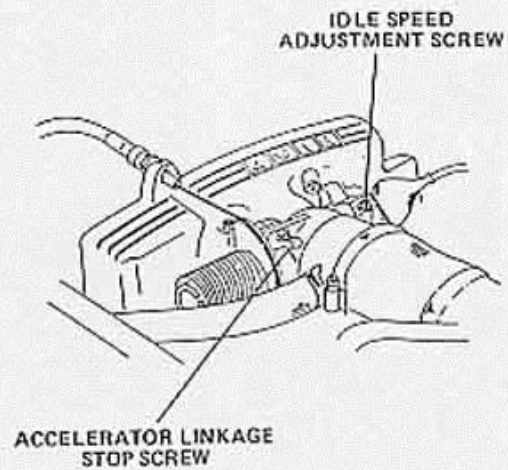

28. Check Accelerator Linkage

Disconnect accelerator linkage from throttle plate lever. Engine idle speed should drop and engine may stall.

- a. If idle speed does not drop, go to check 29.
- b. If idle speed drops, check accelerator linkage for binding and adjustment.

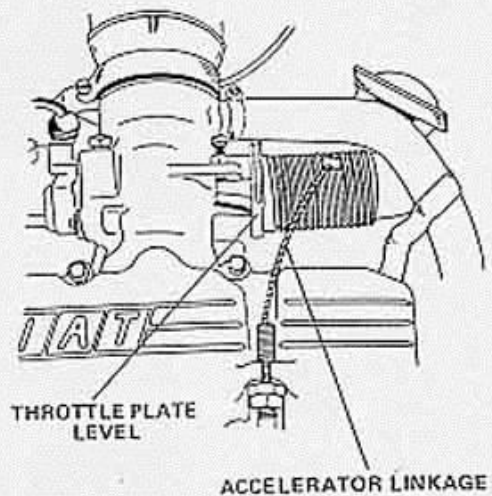

29. Check Throttle Plate for Binding

Push the throttle plate lever toward the closed position in direction of arrow. Engine idle speed should drop.

- a. If idle speed does not drop, go to check 31.
- b. If idle speed drops, go to check 30.

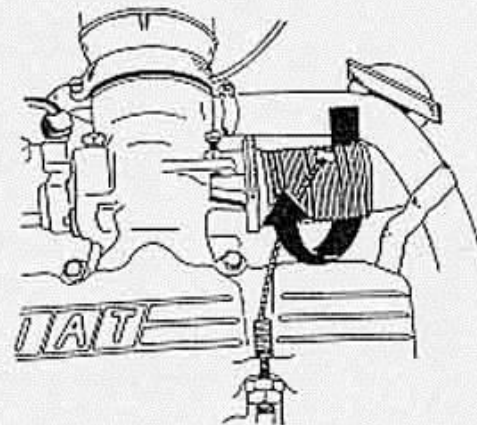

30. Check Throttle Plate Switch for Binding

Remove throttle plate switch from throttle shaft. Check throttle plate for free movement and return to idle. Throttle plate should not bind and should go to idle position.

- a. If throttle plate does not bind, check switch for binding with proper adjustment. See maintenance section.
- b. If throttle plate binds, repair throttle plate, shaft, or replace.

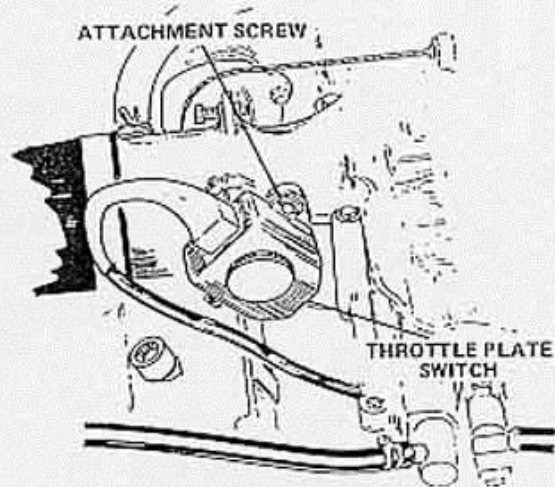

31. Check Air Conditioning Bypass

Make sure air conditioning system is off. Pinch off the air line from the A.C. electrovalve to the intake manifold. Use pinch-off pliers to prevent damage to the hose.

Engine idle speed should not drop.

- a. If idle speed does not drop, go to check 32.
- b. If idle speed does drop, check for voltage at the electrovalve with A.C. off.
 1. If no voltage, replace electrovalve.
 2. If voltage, troubleshoot air conditioning electrical system.

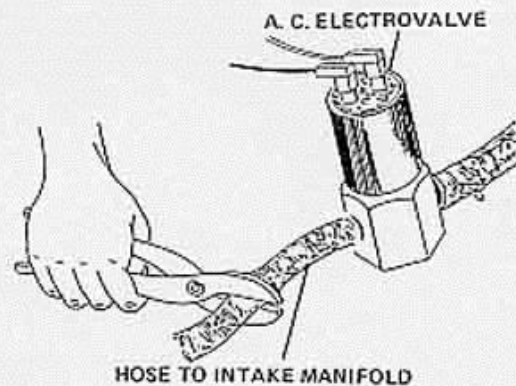

32. Check the Auxiliary Air Regulator

With the engine at normal running temperature, pinch off the air line from the auxiliary air regulator to the intake manifold. Use pinch-off pliers to prevent damage to the hose.

Engine idle speed should not drop.

- a. If idle speed drops, go to check 33.
- b. If idle speed does not drop, check for air leak between throttle plate and intake manifold.

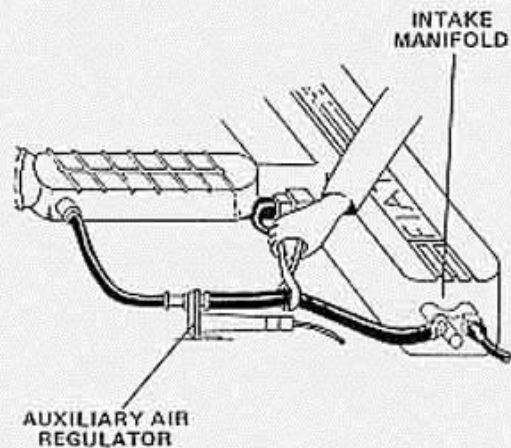

ENGINE IDLES TOO HIGH *(continued)*

33. Check Voltage at Auxiliary Air Regulator

Disconnect the connector from the auxiliary air regulator. See diagram 20, page 52. Connect test light between terminals in connector.

The test light should come on with the engine running.

- a. If test light comes on, replace auxiliary air regulator.
- b. If test light does not come on, check wiring indicated in diagram 20. If wiring is good, replace relay set.

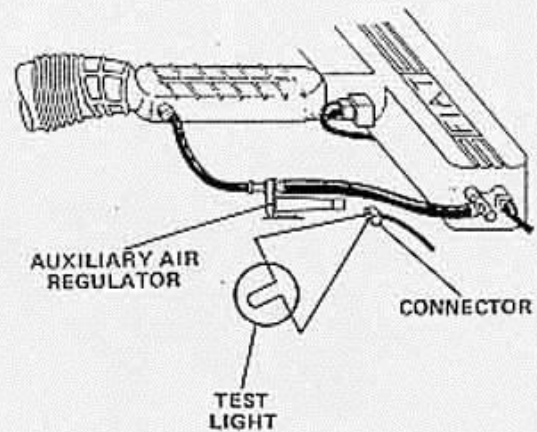

LOW IDLE SPEED OR ROUGH IDLE

34. Perform the checks listed below in the order listed.

1. Adjust engine idle speed as follows:

NOTE: Engine must be at normal operating temperature and the cooling fan off when adjusting idle speed.

- Connect tachometer. Run engine until it reaches normal operating temperature.
- On cars with automatic transmission, apply hand brake and place gearshift lever in "D".
- Turn idle adjustment screw in all the way.
- Adjust stop screw to obtain:
 - Manual Transmission 700 to 800 RPM
 - Automatic Transmission 600 to 700 RPM
- Hold stop screw and tighten locknut.
- Adjust idle speed adjustment screw to obtain:
 - Manual Transmission 800 to 900 RPM
 - Automatic Transmission 700 to 800 RPM
- Hold adjustment screw and tighten locknut.

2. Check the ignition system, check 1, page 1.

NOTE: Perform the check on all spark plugs. If check is good, check that spark plug range is correct. Check spark plug gap.

3. Check that the throttle plate switch is adjusted properly, see maintenance section.

4. Check CO adjustment, see maintenance section.

5. Check air flow sensor, check 8, page 6.

6. Check fuel feed pressure, check 3, page 1.

7. Check coolant temperature sensor resistance, check 5, page 4.

8. Check air temperature sensor resistance, check 23, page 16.

9. Check intake air system, check 2, page 1.

10. Check cold start valve, check 7, page 5.

11. Check injectors for leaks, check 22, page 15.

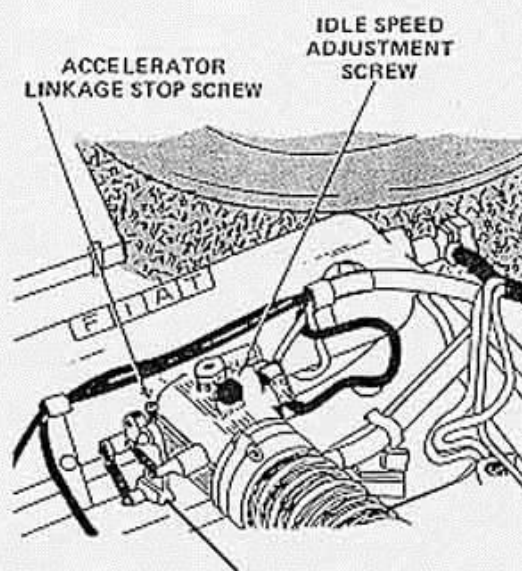

HESITATION

35. Perform the checks listed below in the order listed.

1. Check distributor advance, both centrifugal and vacuum.
2. Check the ignition system, check 1, page 1.
NOTE: Perform the check on all spark plugs. If check is good, check that spark plug range is correct. Check spark plug gap.
3. Check coolant temperature sensor resistance, check 5, page 4.
4. Check air temperature sensor resistance, check 23, page 16.
5. Check air flow sensor, check 8, page 6.
6. Check fuel feed pressure, check 3, page 1.
7. Check intake air system, check 2, page 1.
8. Check cold start valve, check 7, page 5.
9. Check injectors for leaks, check 22, page 15.

INADEQUATE POWER AND POOR PERFORMANCE

36. Perform the checks listed below in the order listed.

1. Check that tire size and air pressure is correct.
2. Check operation of all accessories which affect performance.
3. Check that wheels rotate freely.
4. Check air cleaner for dirt or damage.
5. Check distributor advance, both centrifugal and vacuum.
6. Check valve tappet clearance.
7. Check engine compression.
8. Check clutch for proper operation.
9. Check ignition system, check 1, page 1.

NOTE: Perform check on all spark plugs. If check is good, check that spark plug range is correct. Check spark plug gap.

37. Check Opening of Throttle Plate

Press accelerator pedal to floor and hold it. Check that throttle plate is fully open by pressing throttle plate lever.

Throttle plate should be full open.

- a. If throttle plate is full open, go to check 38.
- b. If throttle plate is not full open, check accelerator linkage.

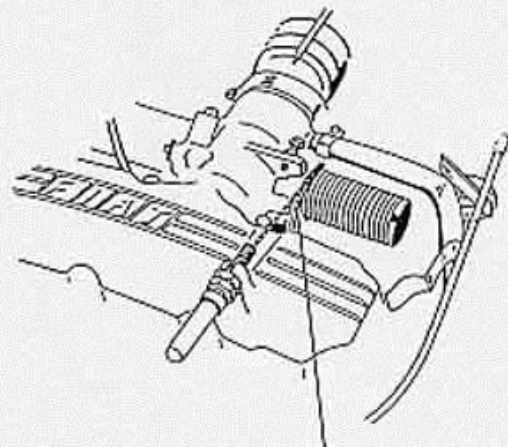

THROTTLE PLATE
LEVER

38. Check Full Throttle Contacts of Throttle Plate Switch

Disconnect connector from control unit. Connect ohmmeter to terminals 3 and 18 of connector. See diagram 21, page 53. Operate throttle linkage and check ohmmeter reading.

With throttle open, meter should read 0 ohms. With throttle closed, meter should read infinity.

- a. If meter reads correctly, go to check 39.
- b. If meter does not read correctly, check adjustment of throttle plate switch, see maintenance section. If switch cannot be adjusted, check wires indicated in diagram 21. If wires are good, replace switch.

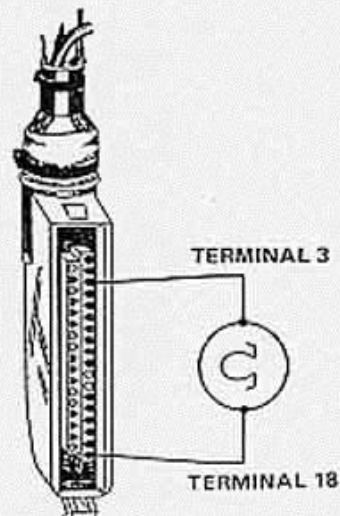

39. Perform the checks listed below in the order listed.

1. Check air flow sensor, check 8, page 6.
2. Check intake air system, check 2, page 1.
3. Check fuel feed pressure, check 3, page 1.

40. Check Fuel Flow

WARNING: FIRE HAZARD

Relieve fuel system pressure.

Disconnect fuel line between fuel pump and filter from the filter. Place hose in a graduated 5 liter container. Turn ignition switch on. Open sensor flap in air flow sensor to close fuel pump contacts.

Fuel flow should be 1.5 to 2 liters after 1 minute.

- a. If fuel flow is not correct, replace pump.
- b. If fuel flow is correct, replace fuel filter. Operate engine. If condition is the same, check fuel lines for blockage or damage.

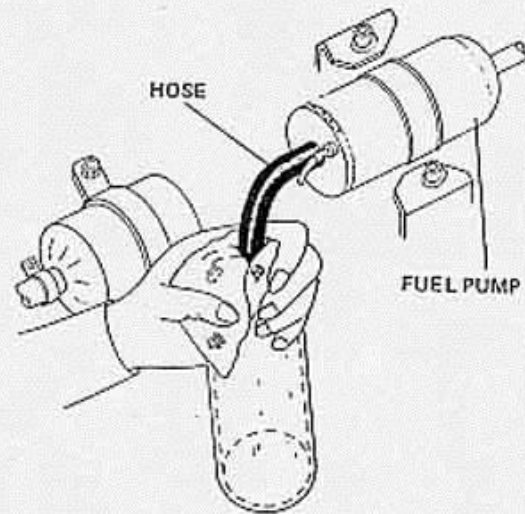

EXCESSIVE FUEL CONSUMPTION

39. Perform the checks listed below in the order listed.

1. Check that tire size and air pressure is correct.
2. Check that the wheels rotate freely.
3. Check distributor advance, both centrifugal and vacuum.
4. Check that the engine reaches normal operating temperature.
5. Check that throttle plate switch is adjusted properly, see maintenance section.
6. Check CO adjustment, see maintenance section.
7. Check air flow sensor, check 8, page 6.
8. Check fuel feed pressure, check 3, page 1.
9. Check coolant temperature sensor resistance, check 5, page 4.
10. Check air temperature sensor resistance, check 23, page 16.
11. Check cold start valve, check 7, page 5.
12. Check injectors for leaks, check 22, page 15.

CO VALUE TOO HIGH

40. Check the distributor advance, both centrifugal and vacuum.

41. Check CO Adjustment, see maintenance section. If CO cannot be adjusted, perform the following checks in the order listed.

1. Check air flow sensor, check 8, page 6.
2. Check fuel feed pressure, check 3, page 1.
3. Check coolant temperature sensor resistance, check 5, page 4.
4. Check air temperature sensor resistance, check 23, page 16.
5. Check cold start valve, check 7, page 5.
6. Check injectors for leaks, check 22, page 15.

ELECTRICAL COMPONENT LOCATION

COMPONENT	X 1/9	STRADA	SPIDER	BRAVA
Electronic Control Unit	Spare wheel compartment	Under dashboard on passenger side		Under dashboard on driver side
Electronic Control Unit Ground	Camshaft housing		Intake manifold	
Auxiliary Air Regulator	Cylinder head near thermostat housing		Cylinder head near timing belt cover	
Thermostat Switch	Cylinder head near spark plugs		Cylinder head below intake manifold	
Cold Start Valve	Intake manifold on driver side		Intake manifold near engine oil dipstick	
Relay Set	Spare wheel compartment	Engine compartment on driver side	Under dashboard on passenger side	Engine compartment on driver side
Air Flow Sensor	Engine compartment on driver side		Engine compartment on passenger side	
Injectors	Intake manifold near head			
Fuel Pump	Engine compartment on driver side	Under vehicle on driver side near rear wheel		
Fuel Pump Ground	Engine compartment on driver side shock tower	Passenger compartment on hand brake mounting bracket	Rear luggage compartment on driver side tail lamp assembly	Rear luggage compartment on passenger side well
Throttle Plate Switch	Intake manifold on throttle shaft			
Coolant Temperature Sensor	Thermostat housing at rear of engine		Coolant union at front of engine	
Lambda Sensor	Exhaust pipe near manifold		Exhaust manifold	
Lambda Sensor Indicator Switch Unit	Behind center console on passenger side	Behind dashboard between radio and glove compartment	Under dashboard on driver side	Under dashboard on passenger side
A. C. Electrovalve	Engine compartment on air flow sensor bracket		N. A.	Engine compartment on firewall

ELECTRICAL DIAGRAM 1

CHECK COOLANT TEMPERATURE SENSOR RESISTANCE

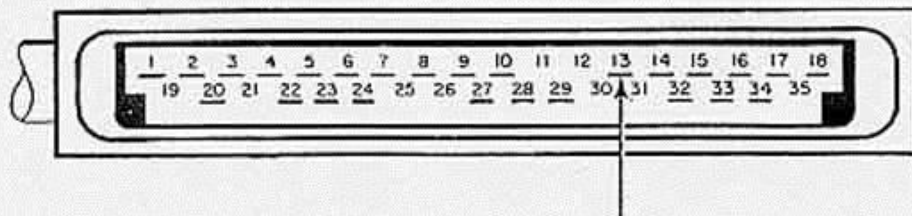
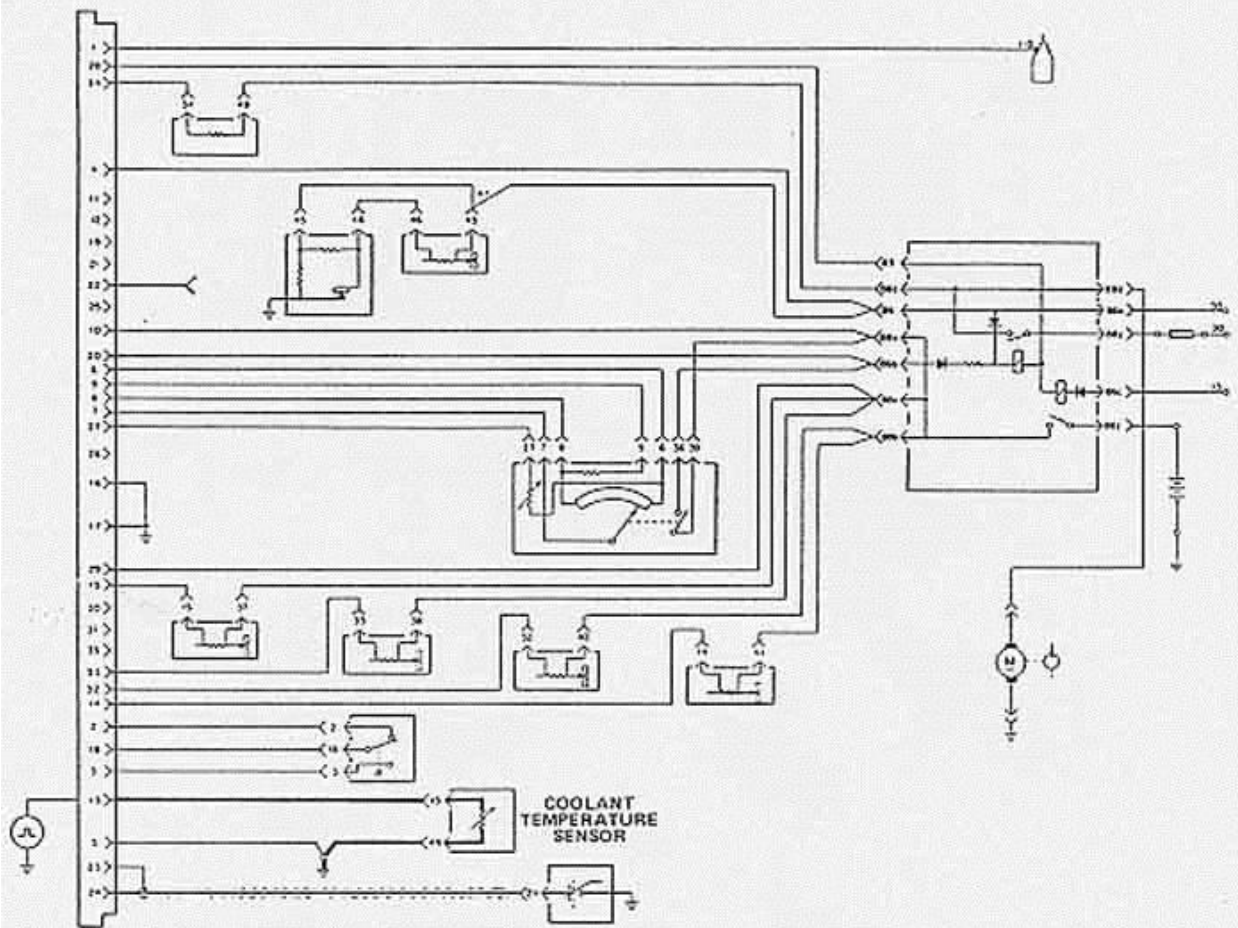

ELECTRICAL DIAGRAM 2

CHECK THERMO TIME SWITCH

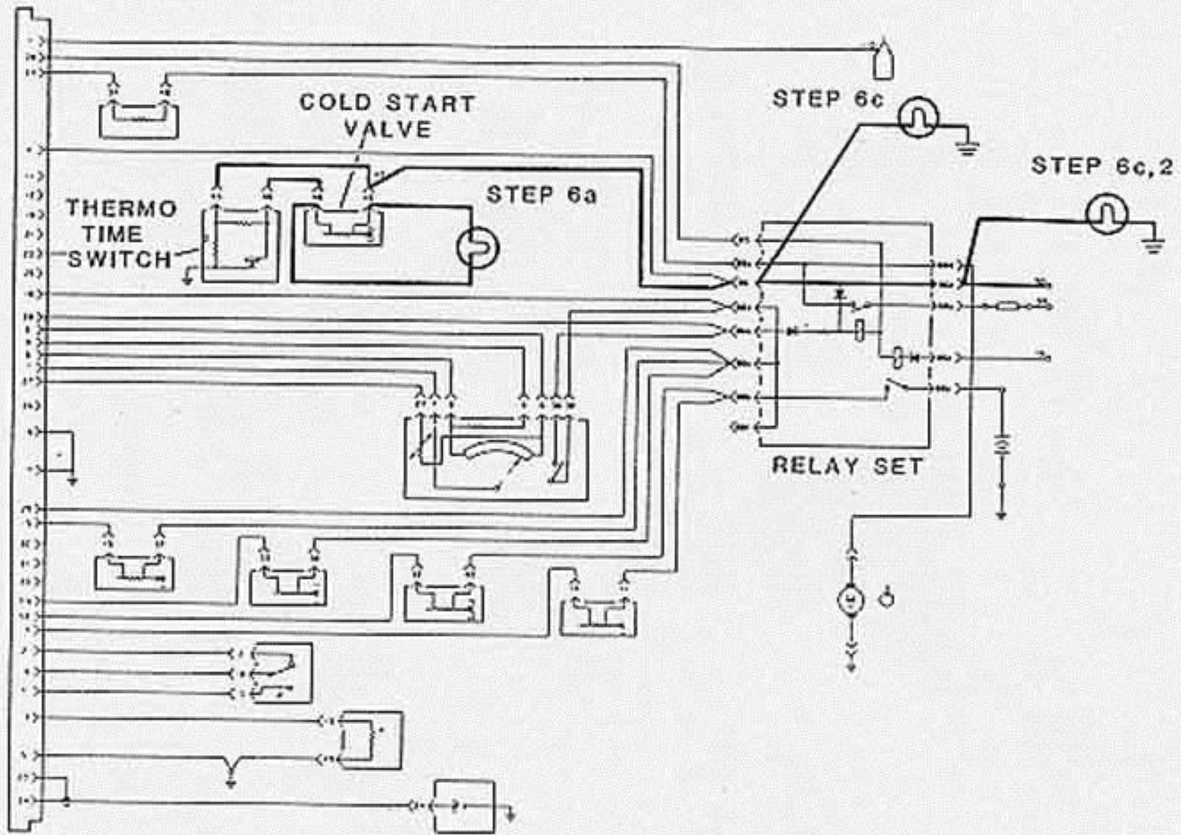

ELECTRICAL DIAGRAM 3

CHECK AIR FLOW SENSOR

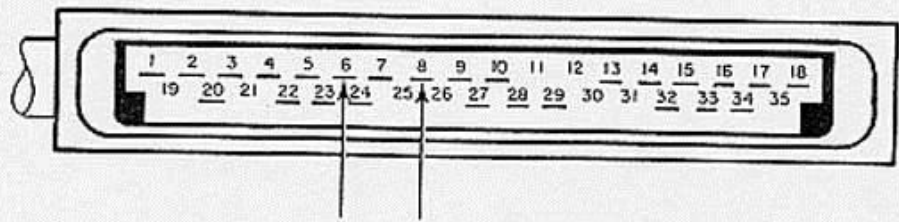
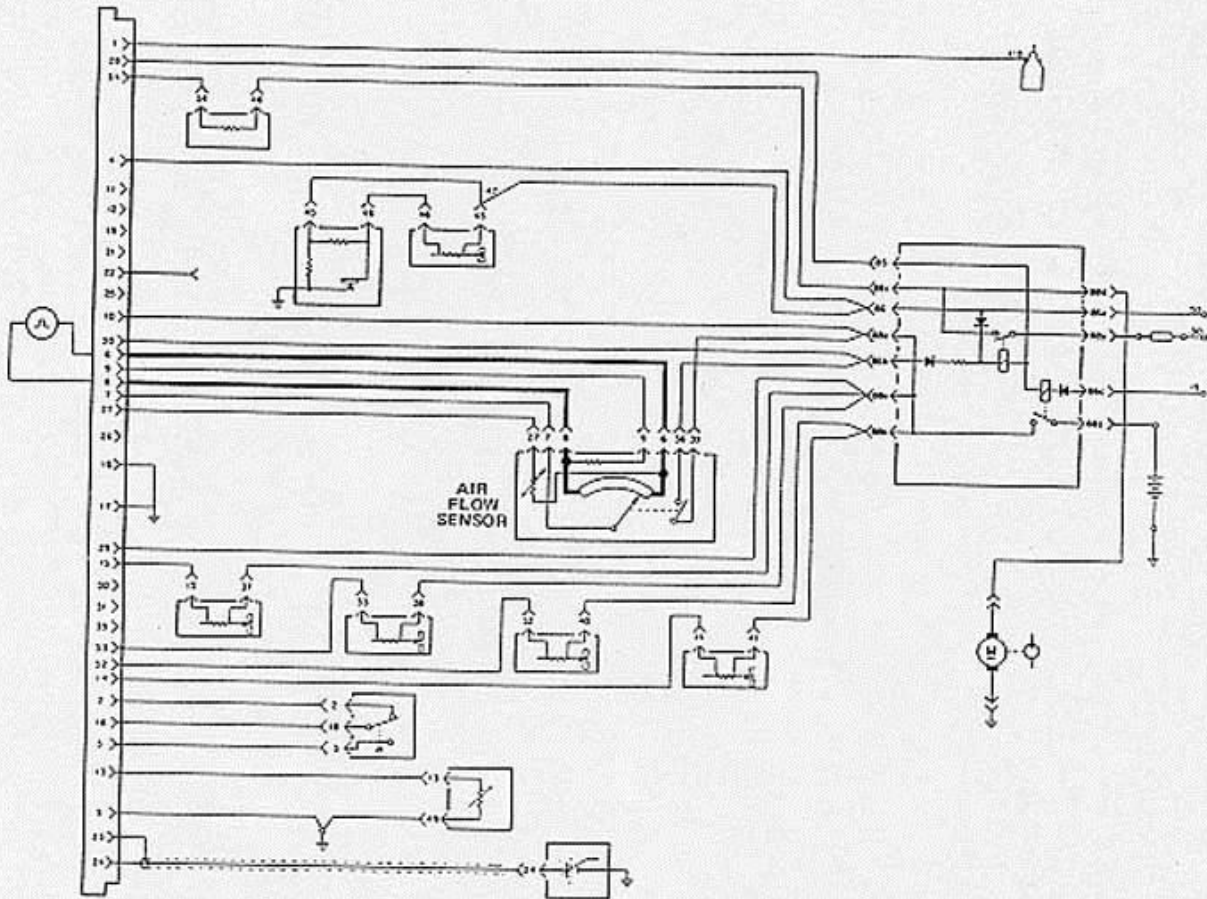

ELECTRICAL DIAGRAM 4

CHECK AIR FLOW SENSOR

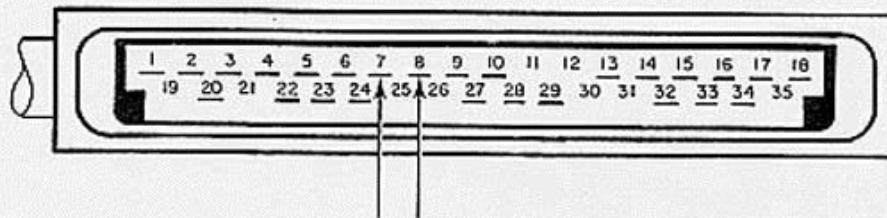
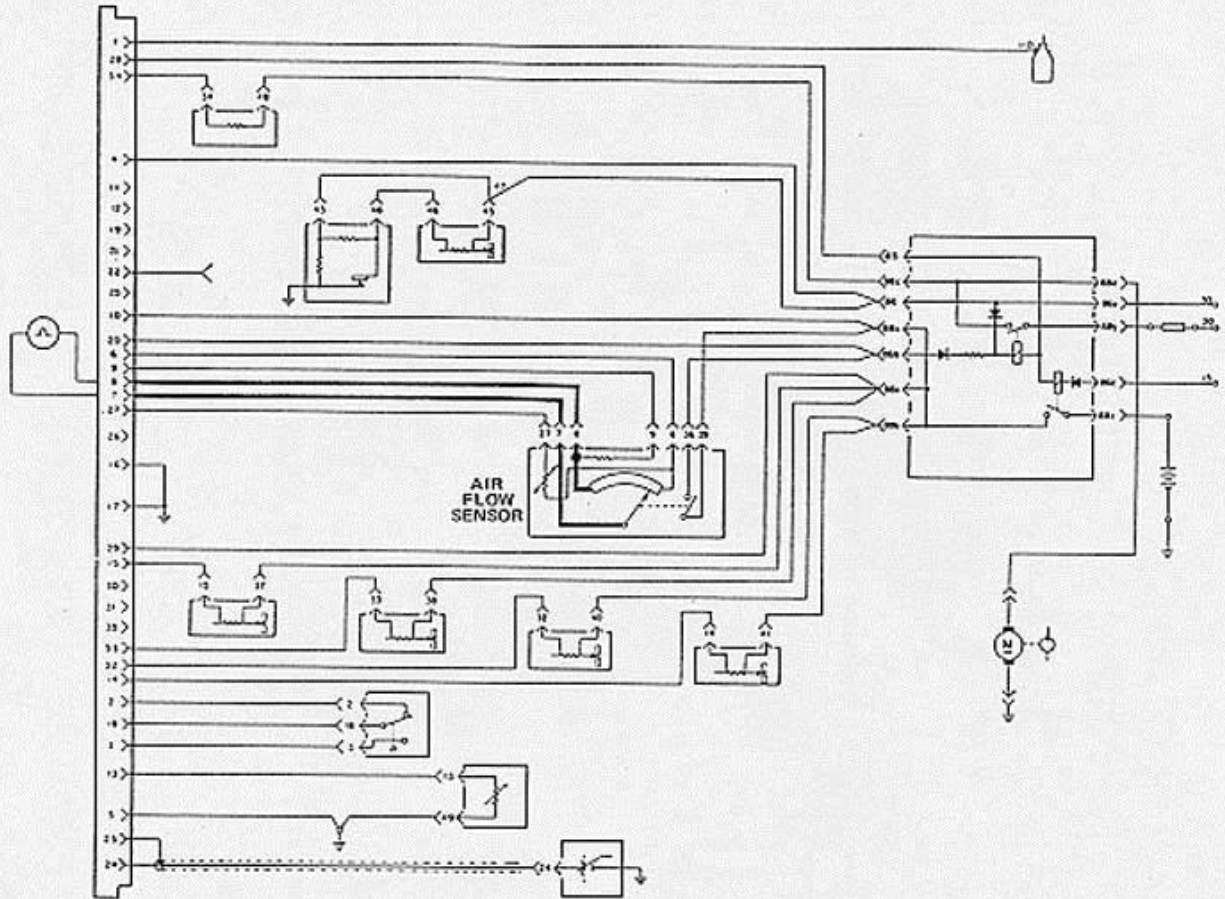

ELECTRICAL DIAGRAM 5

CHECK AIR FLOW SENSOR

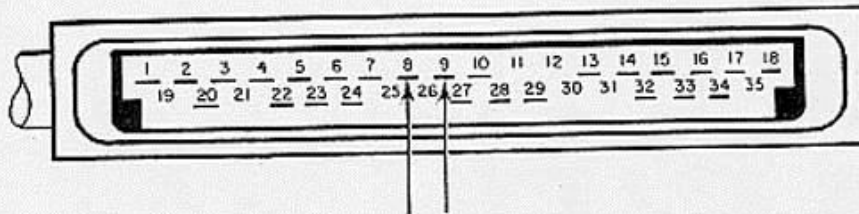
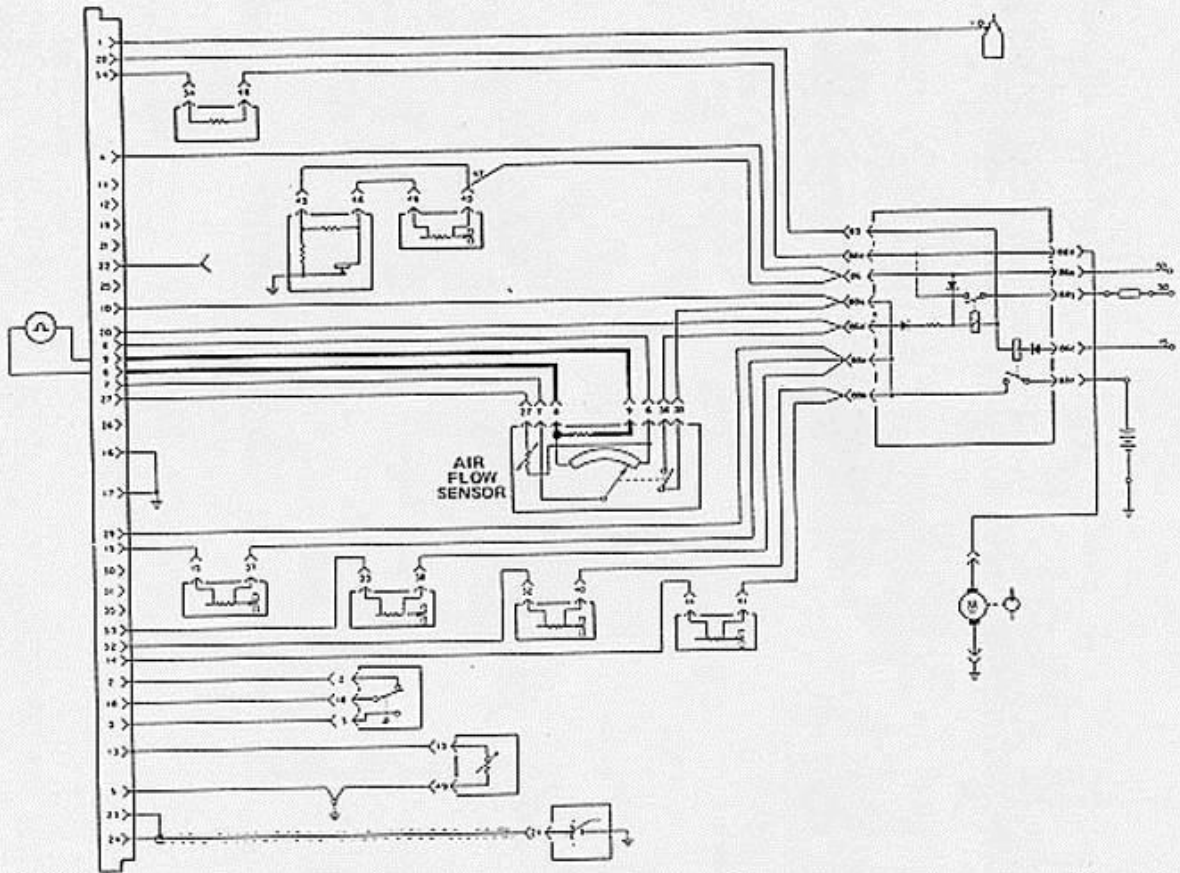

ELECTRICAL DIAGRAM 6

CHECK FOR VOLTAGE OUTPUT TO FUEL PUMP AT RELAY SET

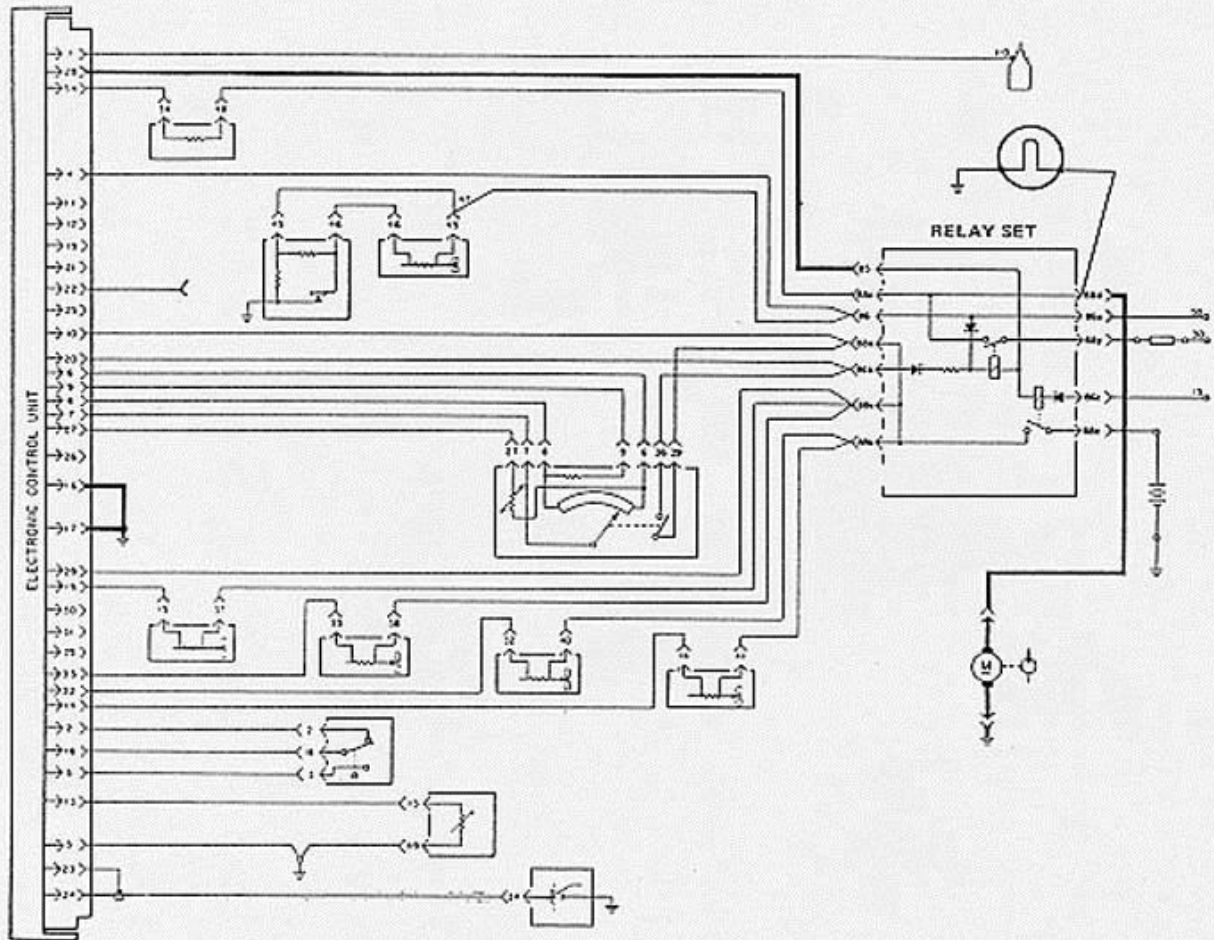

ELECTRICAL DIAGRAM 7

CHECK VOLTAGE INPUT TO RELAY SET FROM IGNITION SWITCH

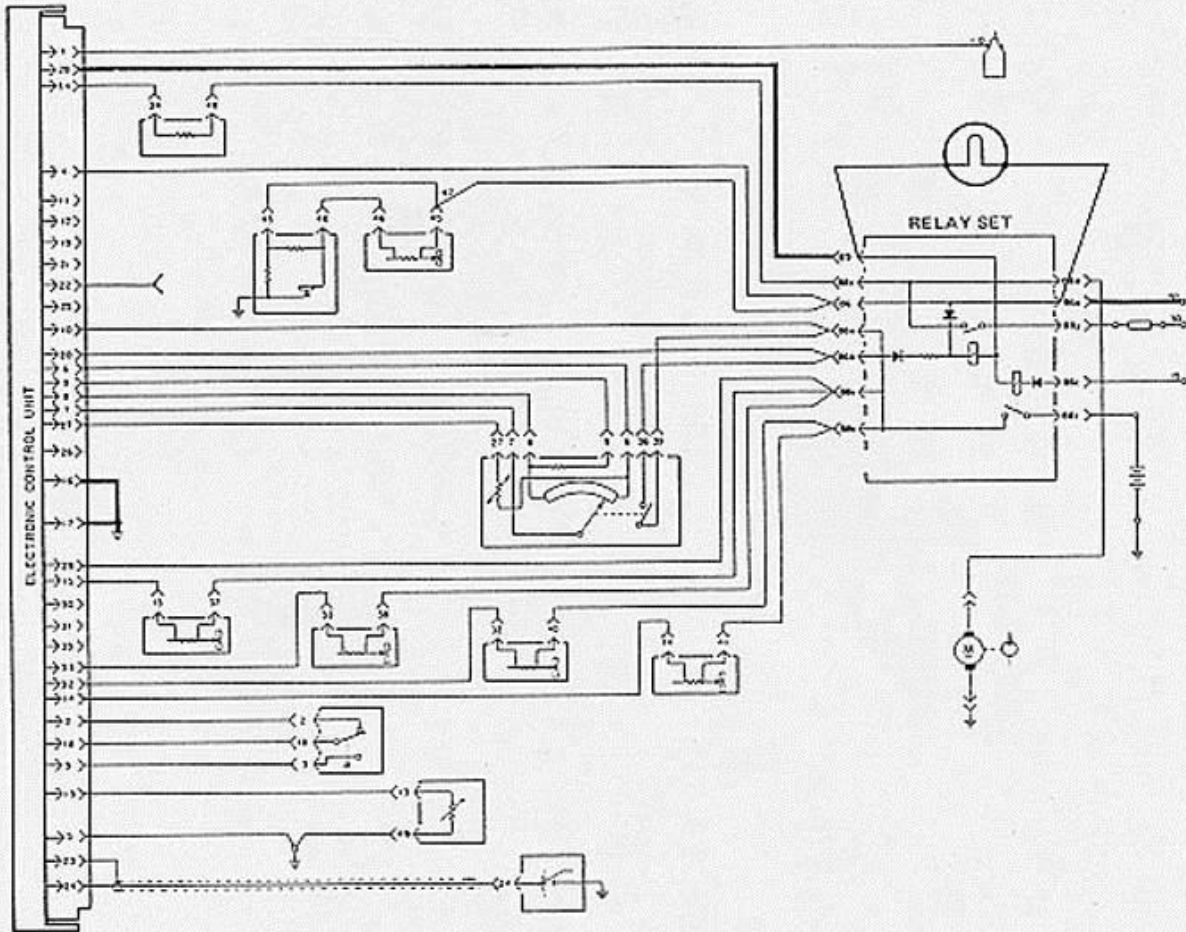

ELECTRICAL DIAGRAM 8

CHECK VOLTAGE INPUT TO FUEL PUMP RELAY OF RELAY SET

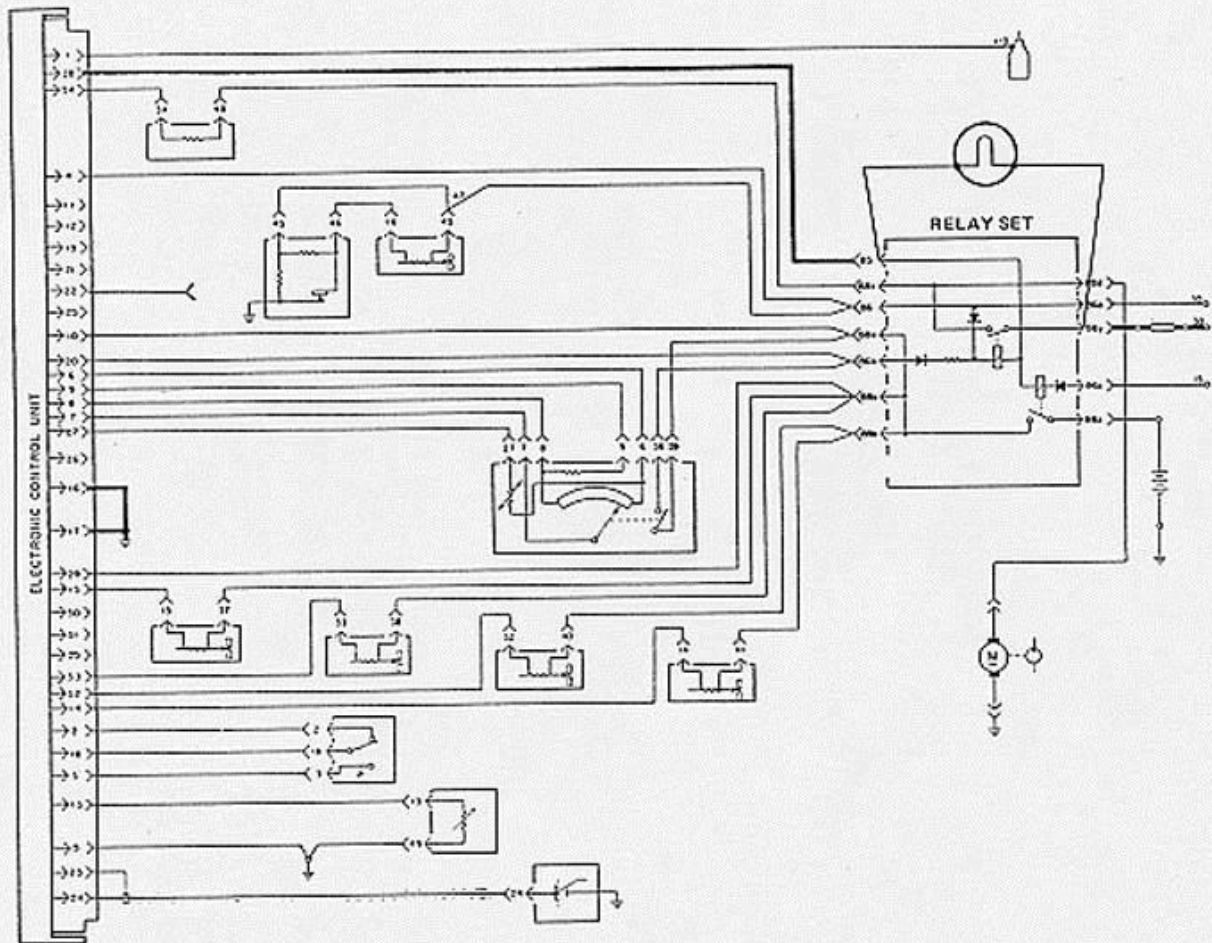

ELECTRICAL DIAGRAM 9

CHECK INPUT VOLTAGE TO CONTROL RELAY OF RELAY SET

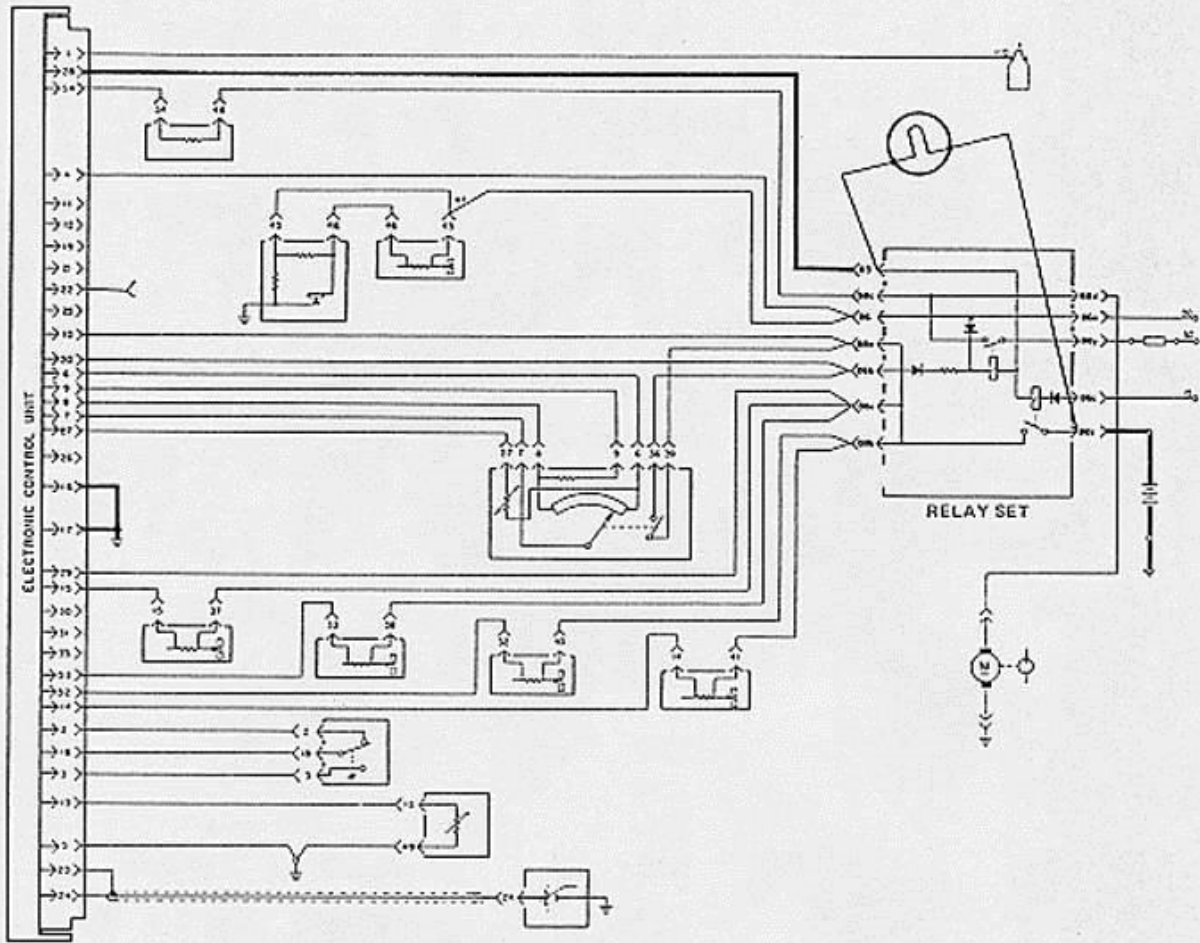

ELECTRICAL DIAGRAM 10

CHECK INPUT VOLTAGE TO CONTROL RELAY OF RELAY SET

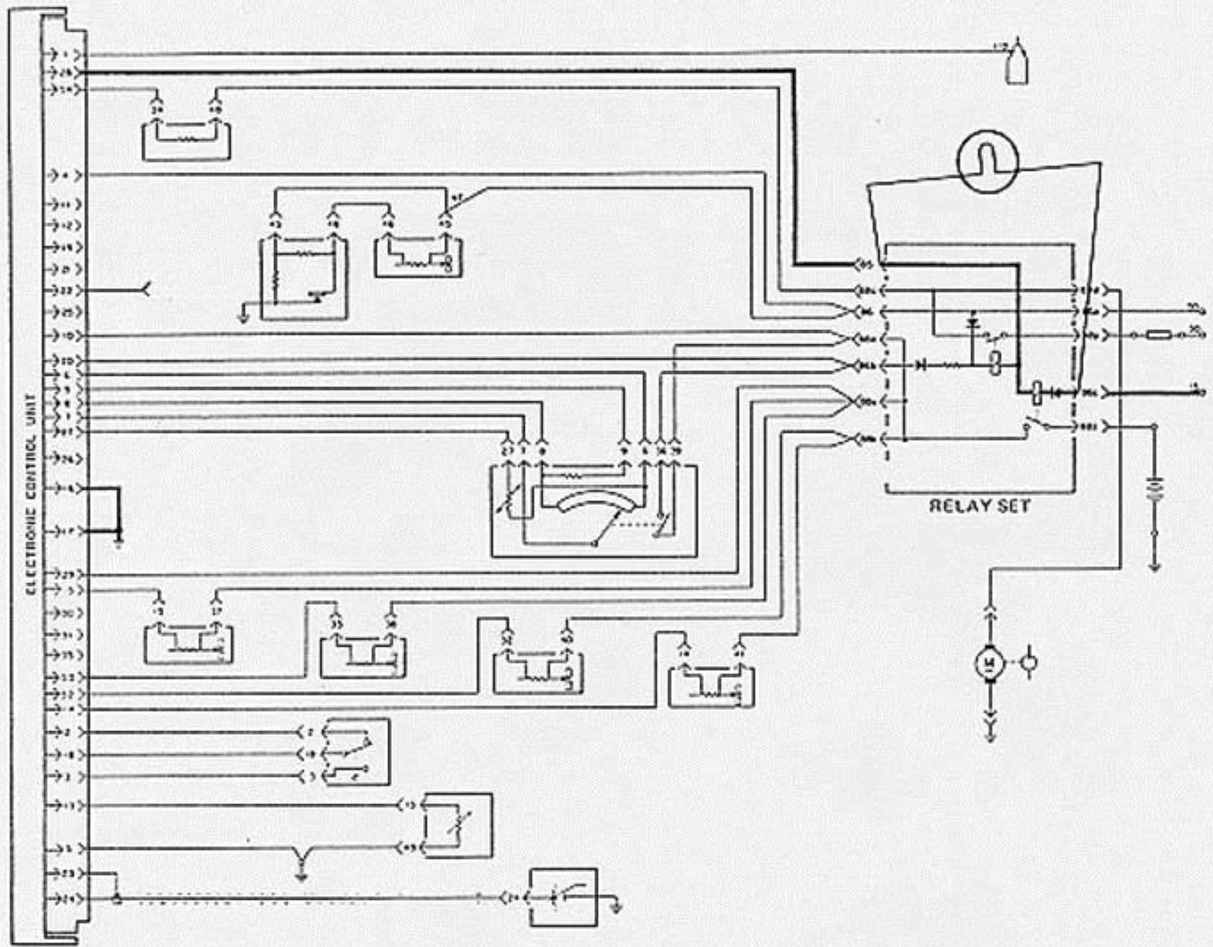

ELECTRICAL DIAGRAM 11

CHECK OUTPUT VOLTAGE FROM CONTROL RELAY OF RELAY SET

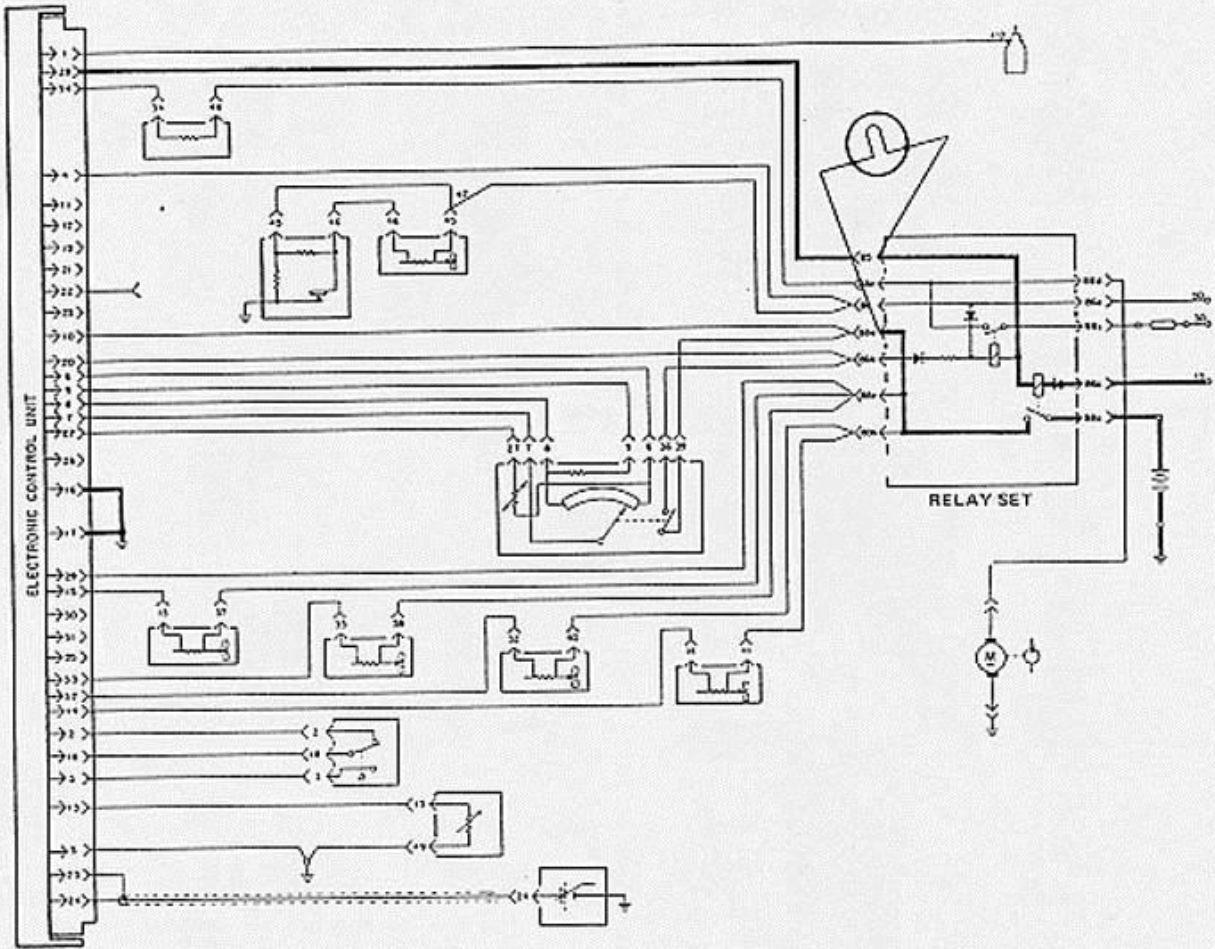

ELECTRICAL DIAGRAM 12

CHECK OUTPUT VOLTAGE FROM CONTROL RELAY OF RELAY SET

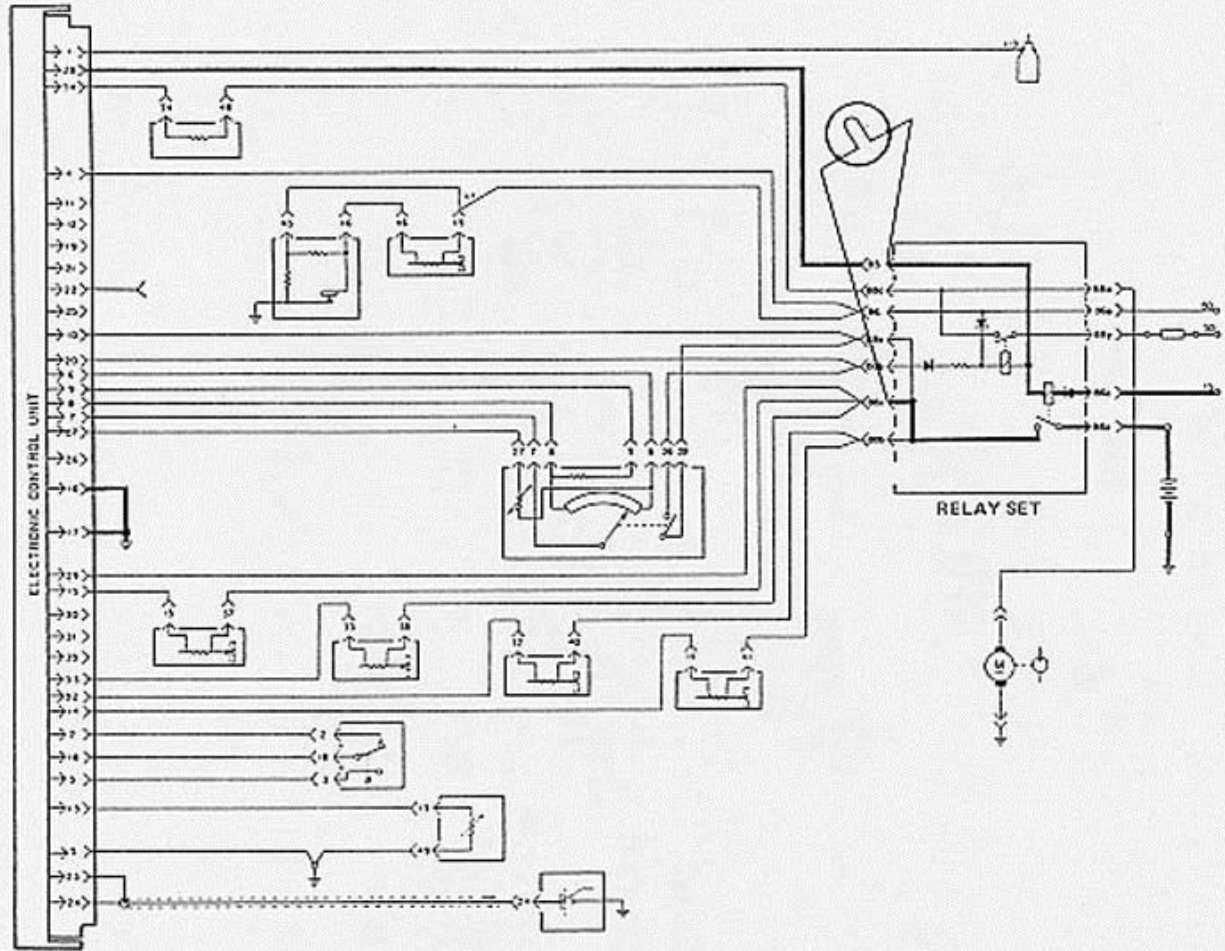

ELECTRICAL DIAGRAM 13

CHECK OUTPUT VOLTAGE FROM CONTROL RELAY OF RELAY SET

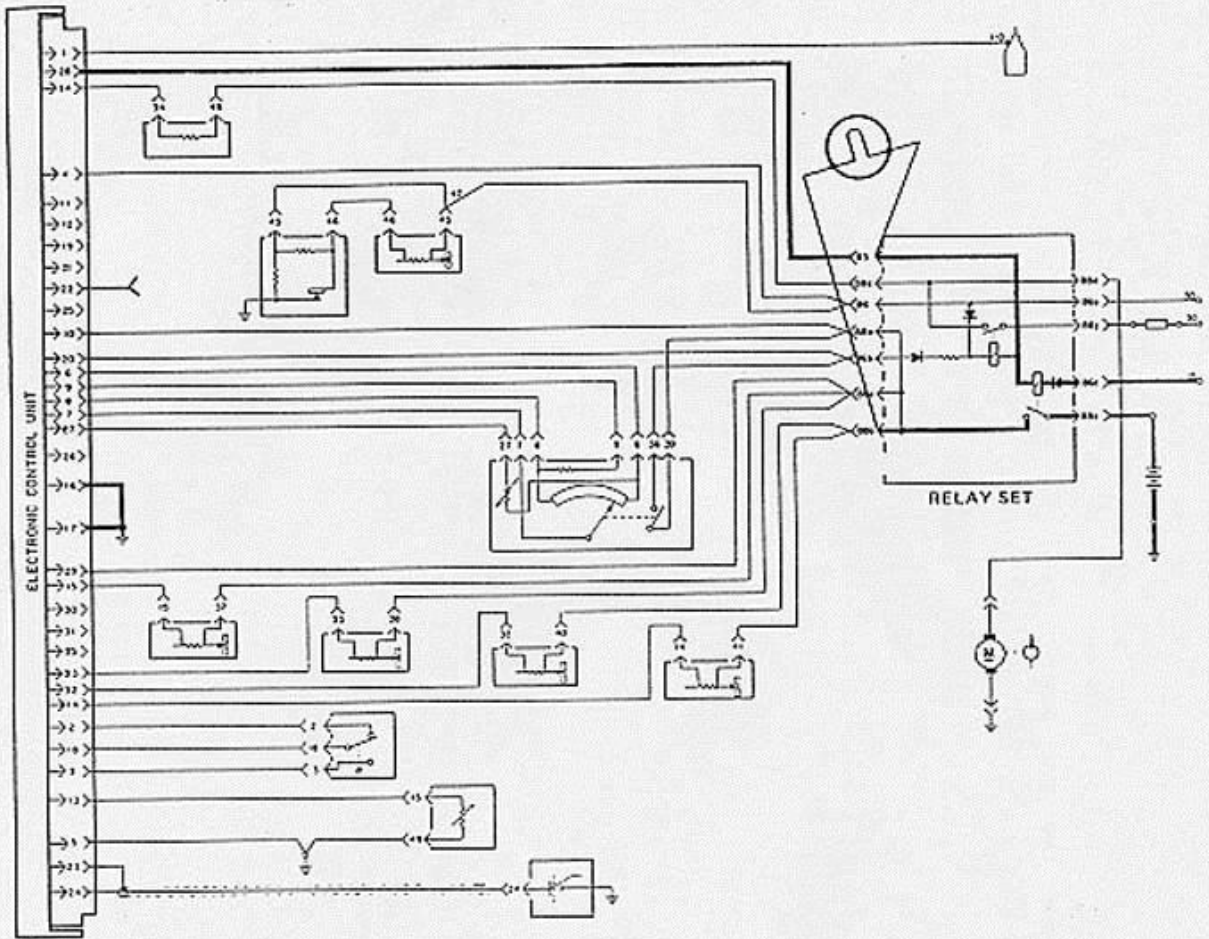

ELECTRICAL DIAGRAM 14

CHECK VOLTAGE SIGNAL FROM COIL TO CONTROL UNIT

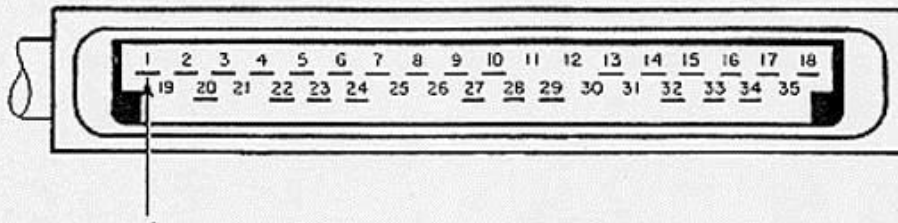
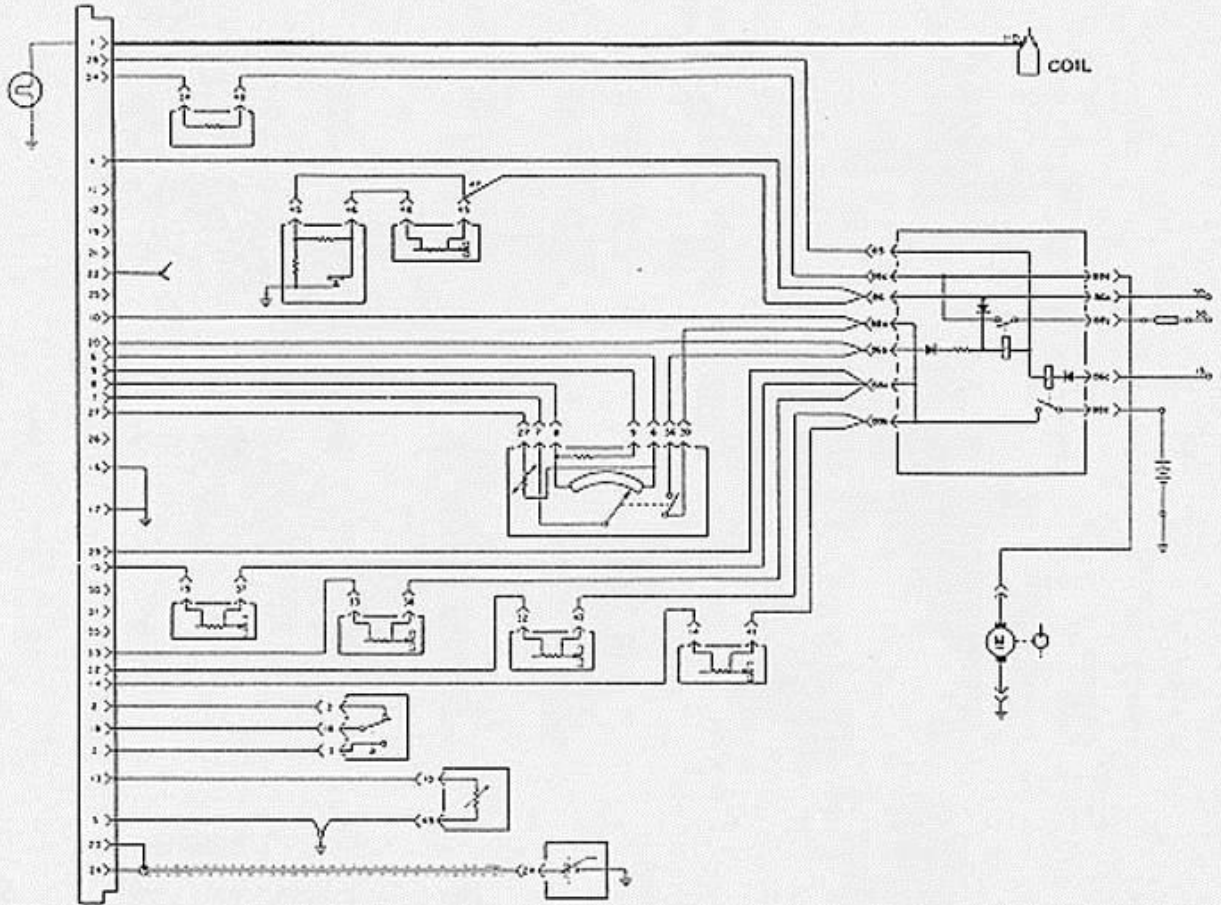

ELECTRICAL DIAGRAM 15

CHECK GROUND CIRCUIT FOR CONTROL UNIT

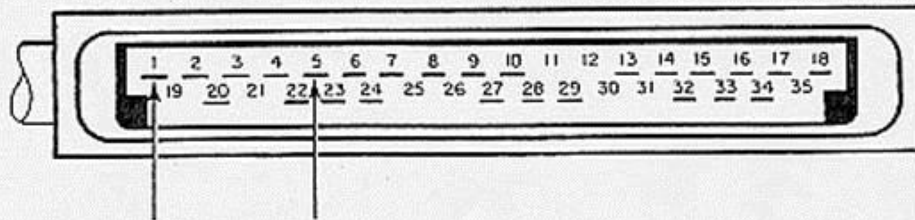
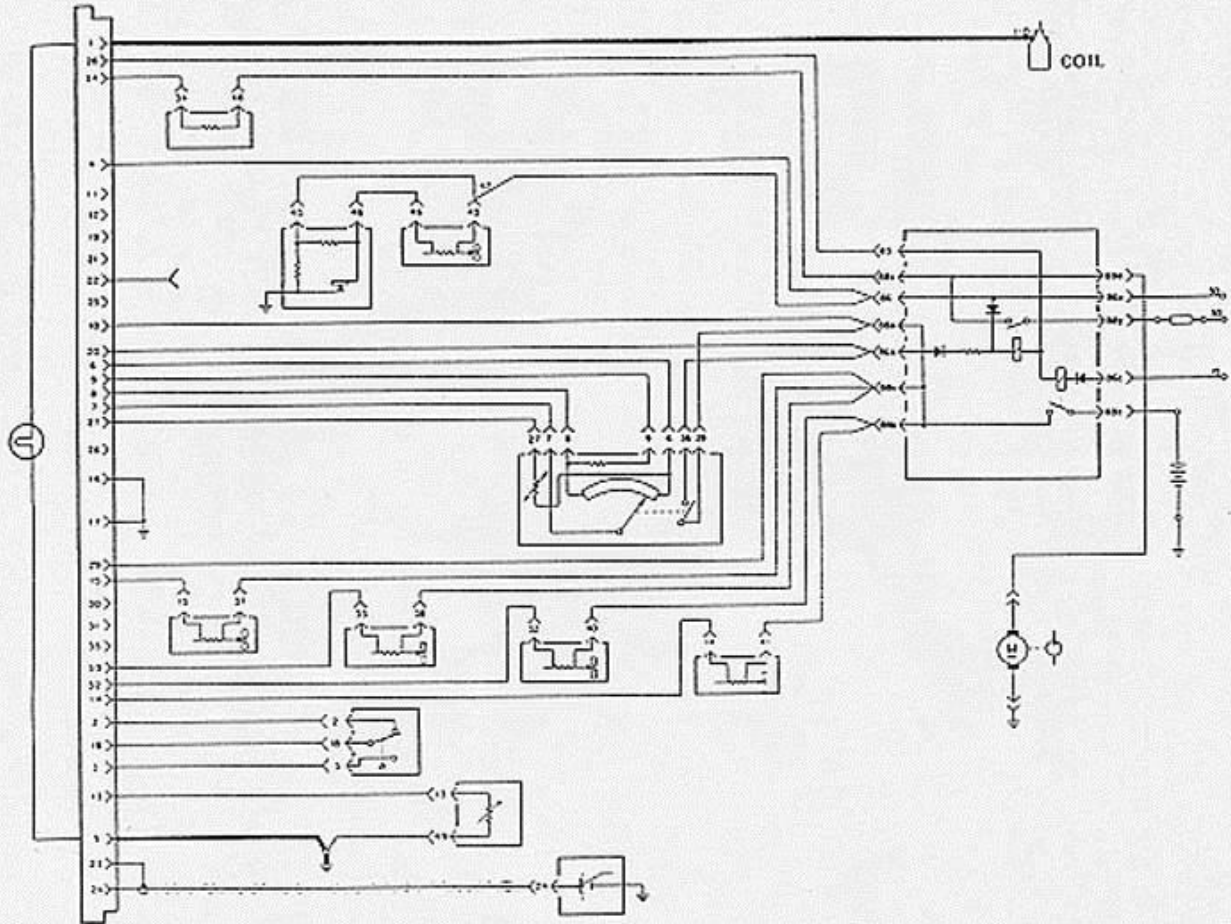

ELECTRICAL DIAGRAM 16

CHECK GROUND CIRCUIT FOR CONTROL UNIT

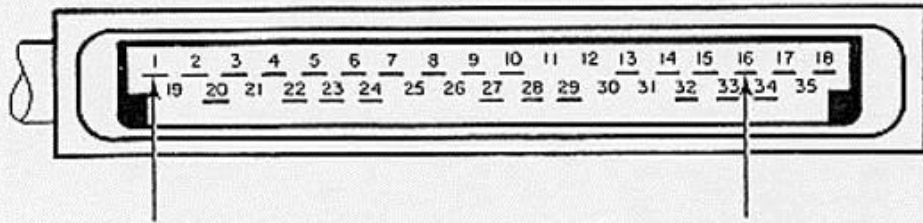
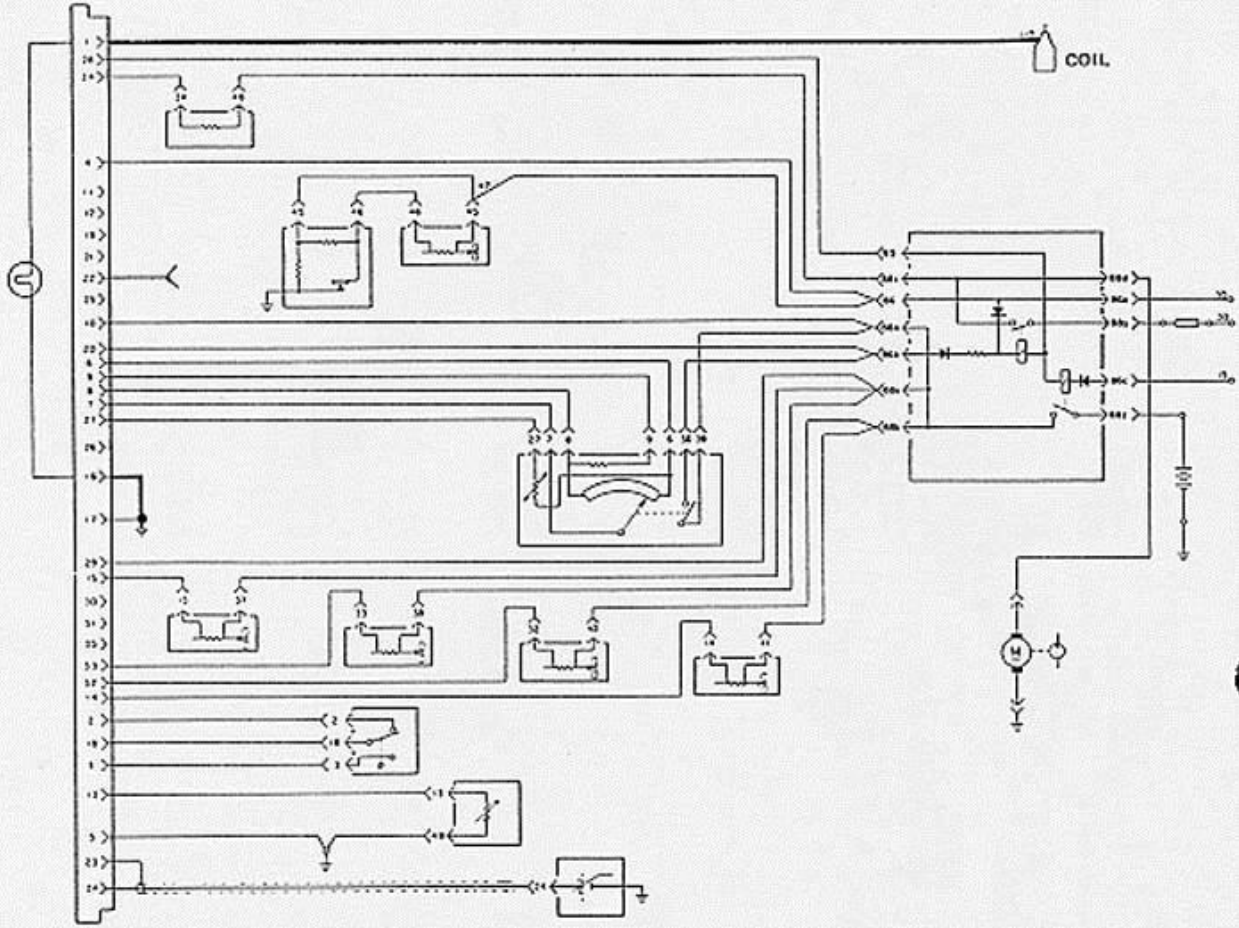

ELECTRICAL DIAGRAM 17

CHECK GROUND CIRCUIT FOR CONTROL UNIT

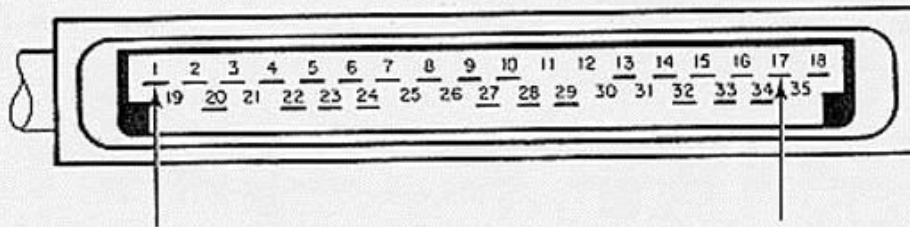
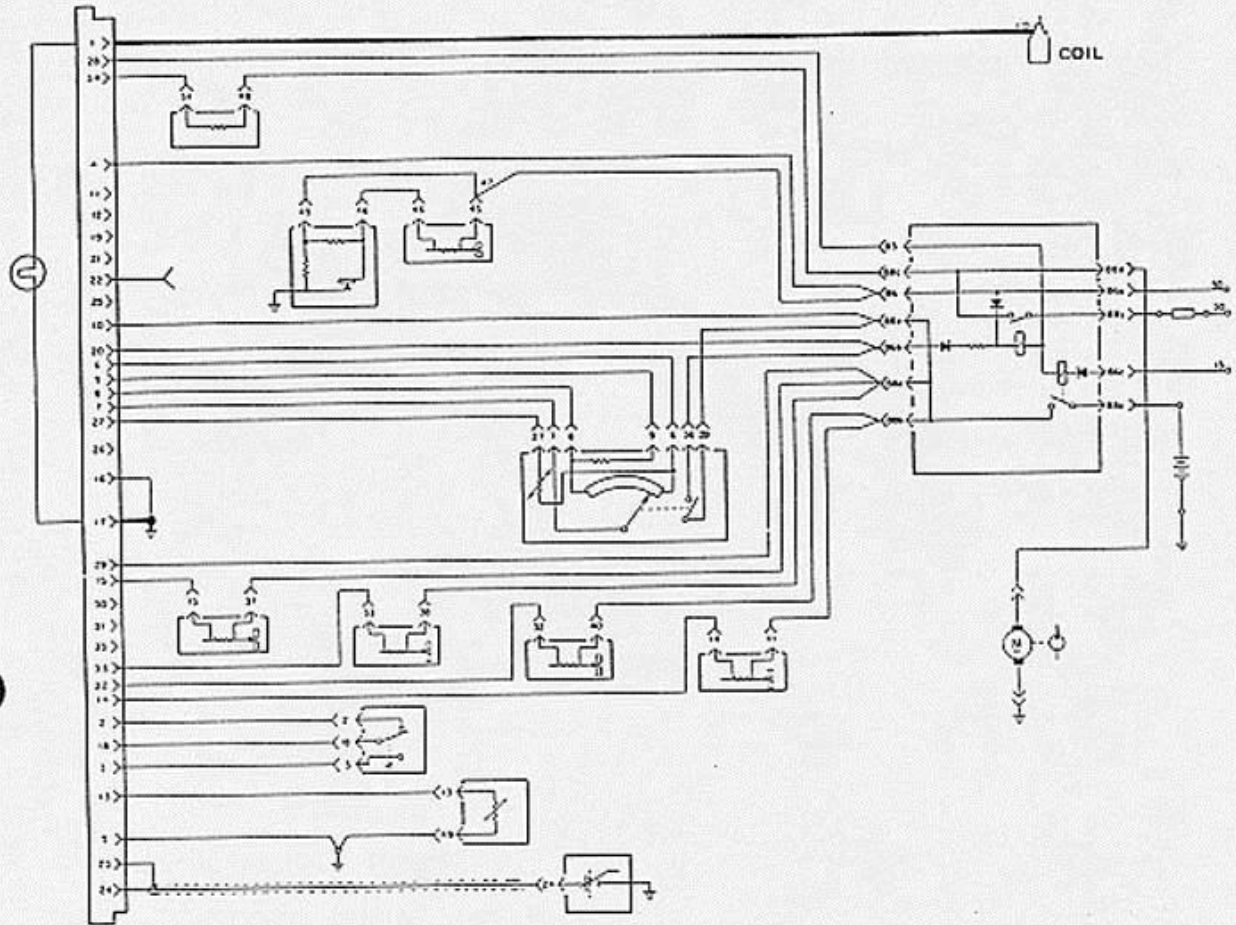

ELECTRICAL DIAGRAM 18

CHECK AIR TEMPERATURE SENSOR RESISTANCE

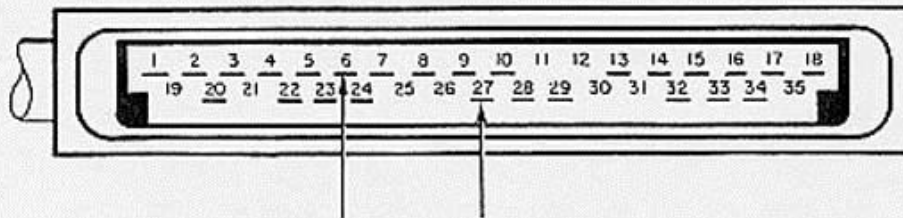
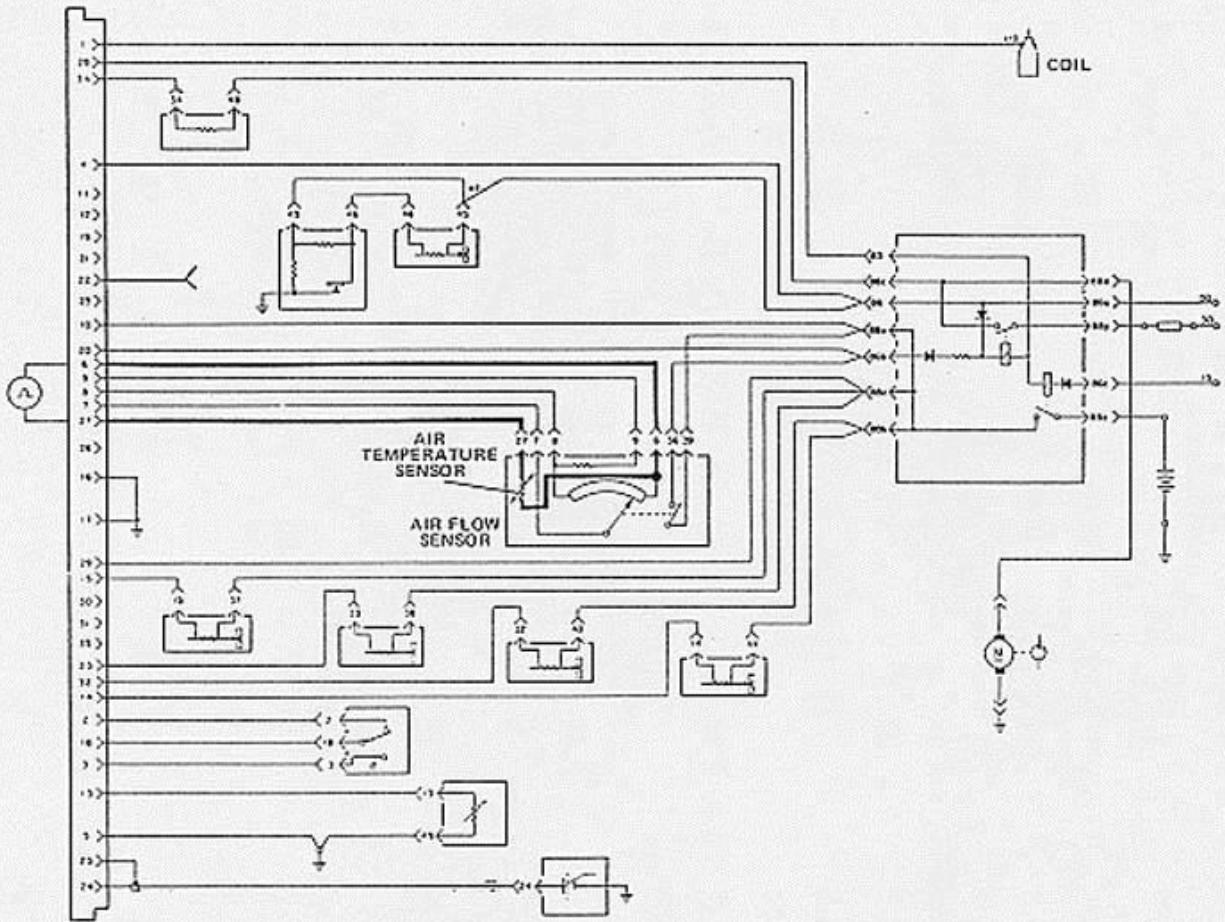

ELECTRICAL DIAGRAM 19

CHECK INPUT TO FUEL PUMP RELAY OF RELAY SET

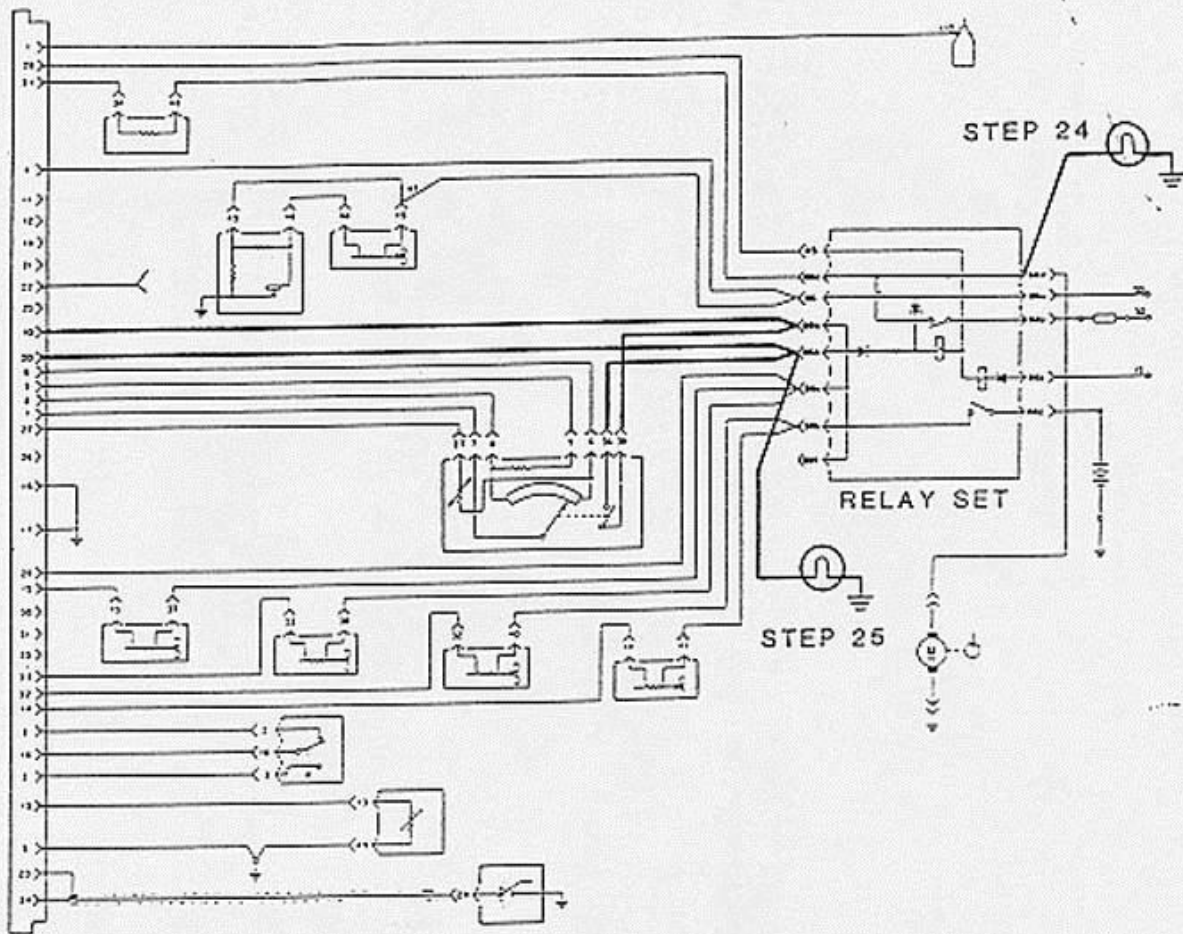

ELECTRICAL DIAGRAM 20

CHECK VOLTAGE AT AUXILIARY AIR REGULATOR ..

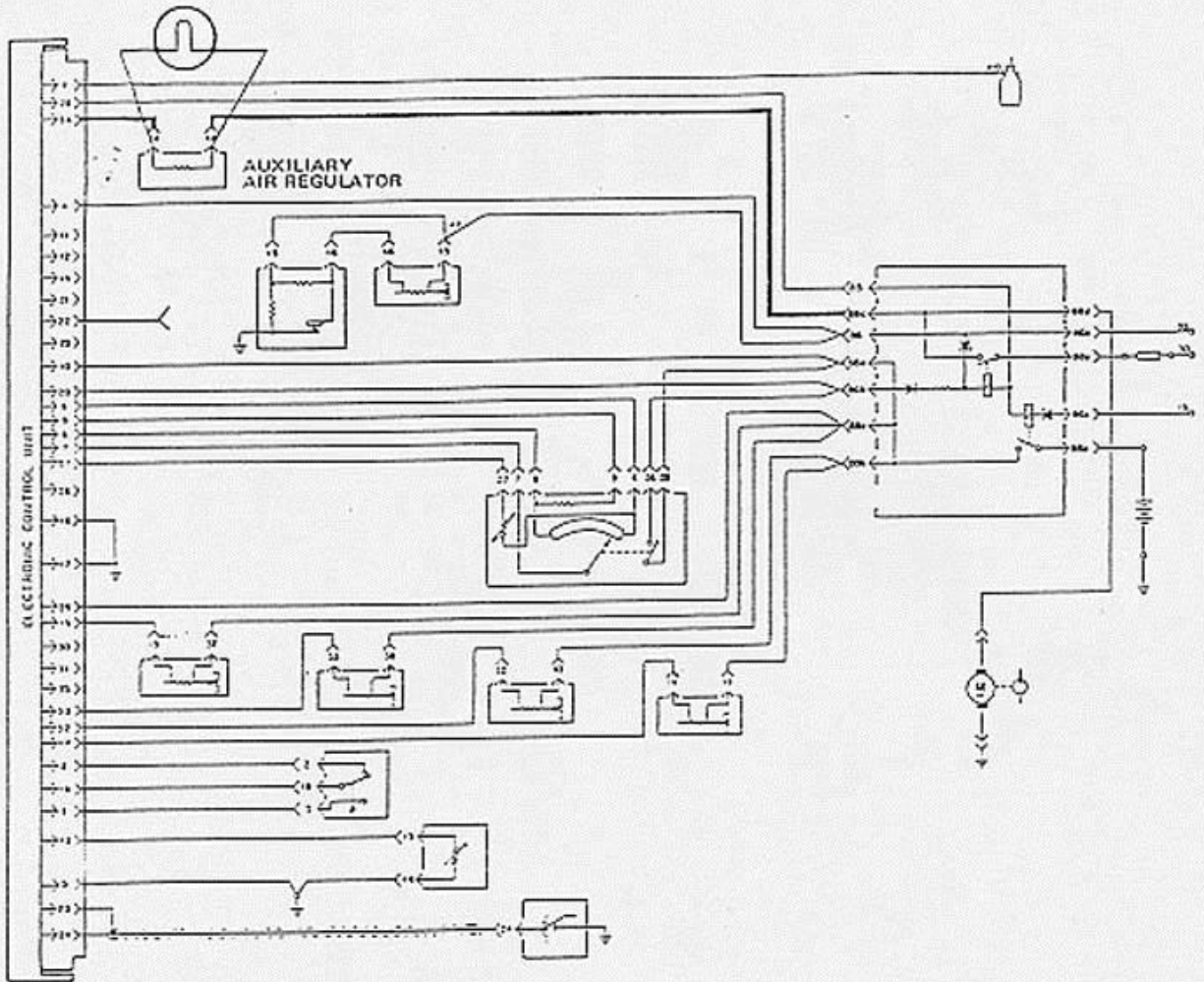

ELECTRICAL DIAGRAM 21

CHECK FULL THROTTLE CONTACTS OF THROTTLE PLATE SWITCH

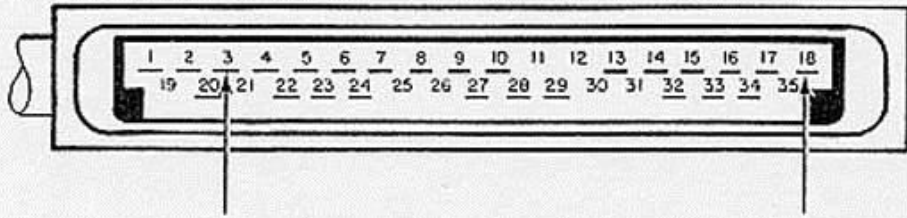
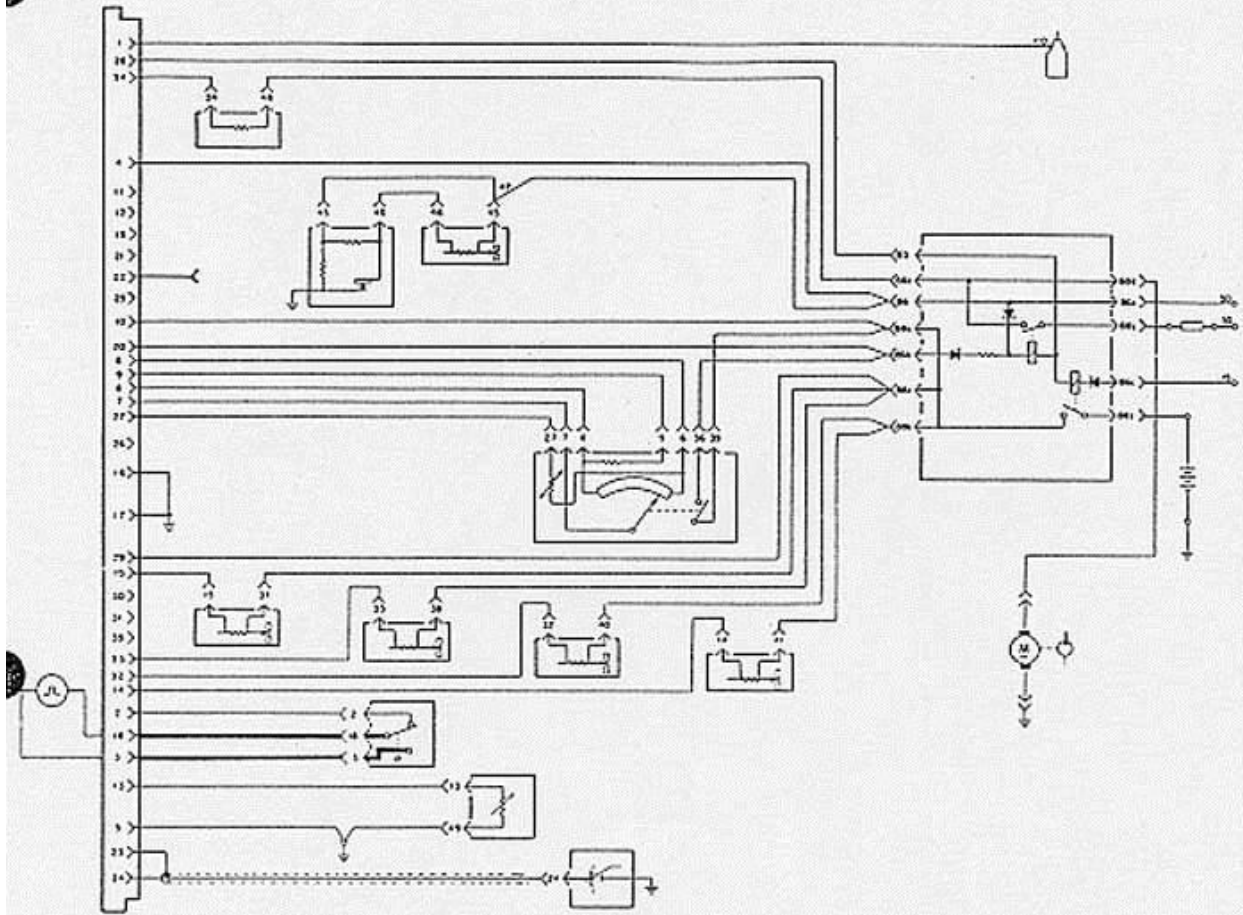

Air Cleaner Filter Replacement

NOTE: The air filter element should be changed every 30,000 miles. If vehicle is frequently driven in heavy traffic or sandy or dusty areas, it is recommended to replace filter every 15,000 miles.

- Remove wing nut securing cover to filter housing.
- Remove cover and remove filter. Install new filter and reinstall cover with wing nut.

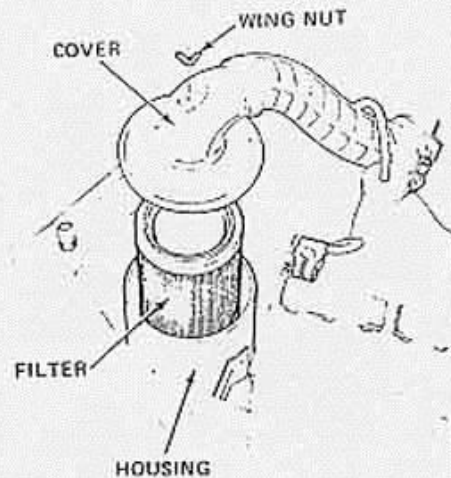

Idle Speed Adjustment

NOTE: Engine must be at normal operating temperature and the cooling fan off when adjusting idle speed.

- Connect tachometer. Run engine until it reaches normal operating temperature.
- On cars with automatic transmission, apply hand brake and place gearshift lever in "D".
- Adjust idle speed adjustment screw to obtain:
 - Manual Transmission 800 to 900 RPM
 - Automatic Transmission 700 to 800 RPM
- Hold adjustment screw and tighten the locknut.
- If idle speed cannot be set to proper speed or if throttle linkage or intake manifold was replaced, adjust accelerator linkage stop screw as described below.

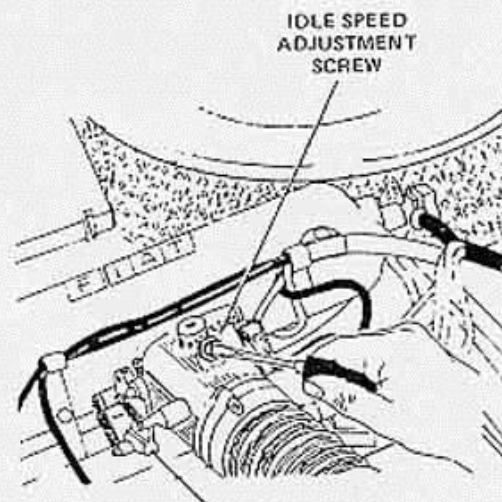

Accelerator Linkage Stop Screw Adjustment

NOTE: Perform this adjustment if idle speed cannot be set low enough or if throttle linkage or intake manifold was replaced.

- Connect tachometer. Run engine until it reaches normal operating temperature.

NOTE: Engine cooling fan must be off during this adjustment.

- On cars with automatic transmission, apply hand brake and place gearshift lever in "D".
- Turn idle speed adjustment screw in all the way.
- Adjust stop screw to obtain:
 - Manual Transmission 700 to 800 RPM
 - Automatic Transmission 600 to 700 RPM
- Hold stop screw and tighten the locknut.
- Adjust idle speed adjustment screw.

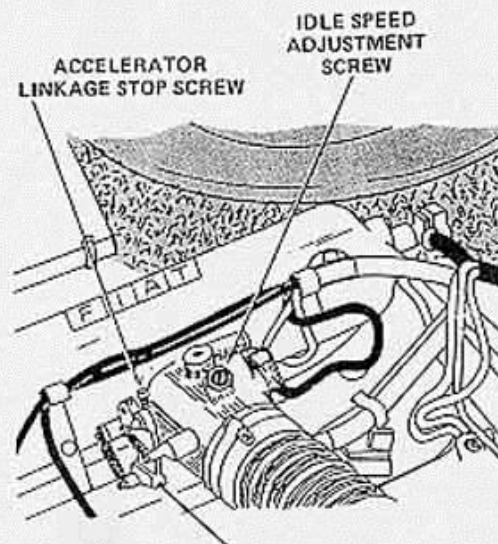

Idle CO Adjustment

NOTE: CO is set at the factory and no further adjustment is necessary unless a fuel injection component is replaced.

- Install the adapter kit on your CO Analyzer.

NOTE: The adapter kit contains instructions for installing the kit on your Analyzer.

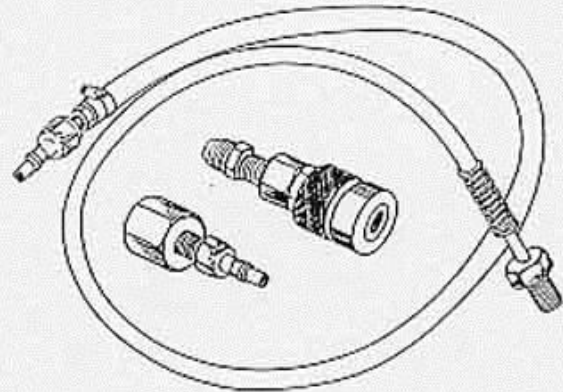

- Remove plug from CO pickup fitting near catalytic converter. Install the adapter nipple in the pickup. Connect hose from CO analyzer to nipple.
- Make sure there is no air leaking into the intake air system.
- Make sure idle speed is set correctly.

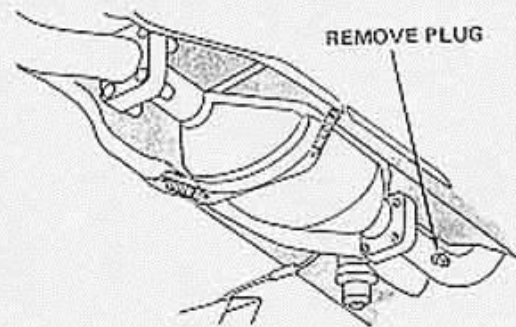

- Turn analyzer on and set it according to manufacturers' instructions.
- Disconnect wire from Lambda sensor. Make sure neither wire can ground out.
- Run engine until normal operating temperature is reached.

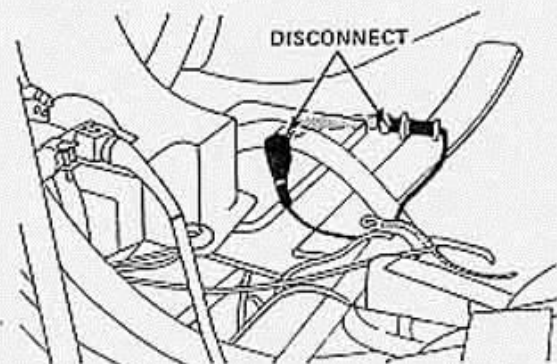

MAINTENANCE

1500 CC ENGINE

Page 57

- Remove aluminum plug from air flow sensor.
- Turn CO adjustment screw to set CO to $0.7\% \pm 0.2\%$.
 - clockwise – increase CO
 - counterclockwise – decrease CO
- Ground harness wire for Lambda sensor and check reading. CO reading should be at least 1.5%.
- Connect wire to Lambda sensor and check reading. CO reading must be between 0.3 and 0.6%.

WARNING: In next set, be very careful in removing nipple and installing plug. Exhaust pipe could be very hot.

- If reading is correct, remove analyzer nipple and install plug in pickup.
- Install replacement aluminum plug in air flow sensor.

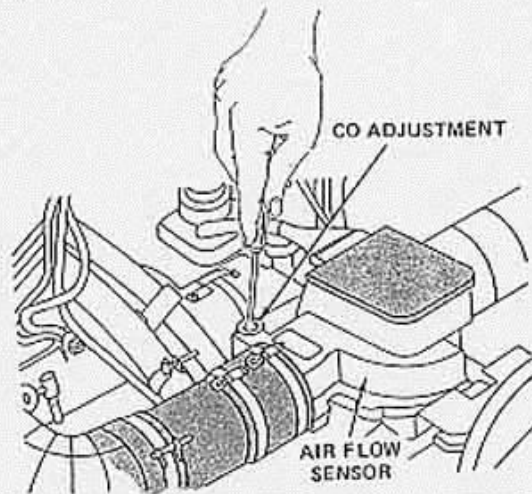

Accelerator and Kick-Down Cable Adjustment

- Make sure engine idle speed is set correctly.
- Check that there is a 10 cm (4 inch) accelerator pedal travel. If not, bend pedal rod.
- With accelerator pedal fully pressed (including kick-down), check that linkage A is at full travel up. If not, adjust 17 mm adjusting nuts.

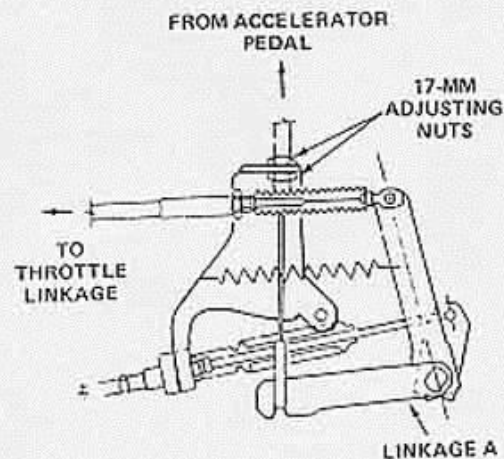

- With accelerator pedal fully pressed (including kick-down), check that there is a wide open throttle and that the cable is pulled from its stop about 13 mm ($\frac{1}{2}$ inch). If not, adjust 14 mm adjusting nuts.

NOTE: It may also be necessary to adjust throttle linkage stop screw to obtain wide open throttle.

- Release accelerator pedal and check that the throttle closes. If not, adjust throttle shaft cable by loosening 8 mm locknut and rotating cable end until socket can be freely installed, then tighten locknut.

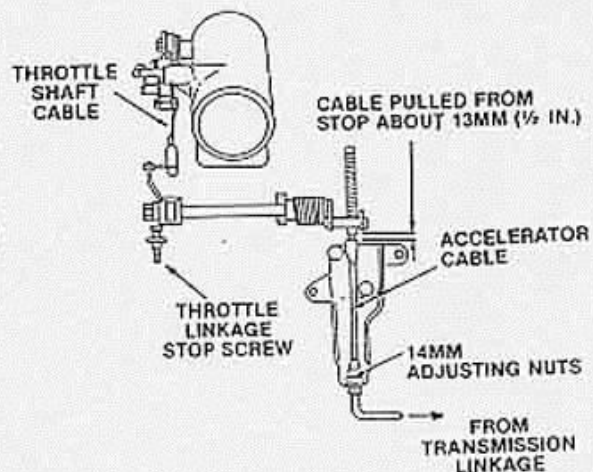

Throttle Plate Switch Adjustment

- Make sure idle speed is correct.
- Disconnect connector from throttle plate switch.
- Connect an ohmmeter between terminals 2 and 18 of the switch.

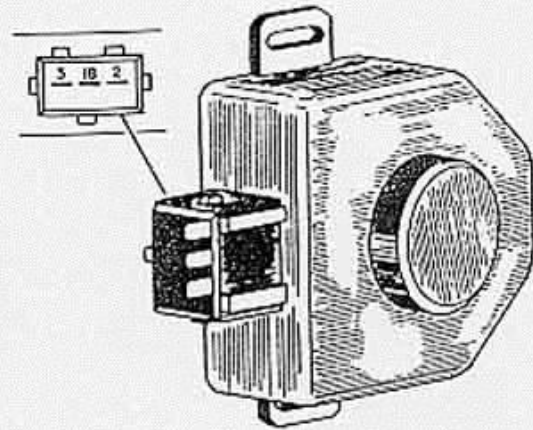

- Loosen two screws holding throttle plate switch.
- With engine off, rotate switch clockwise until ohmmeter indicates closed circuit.
- At the exact point ohmmeter indicates closed circuit, tighten the two screws holding the switch.
- Check the adjustment.

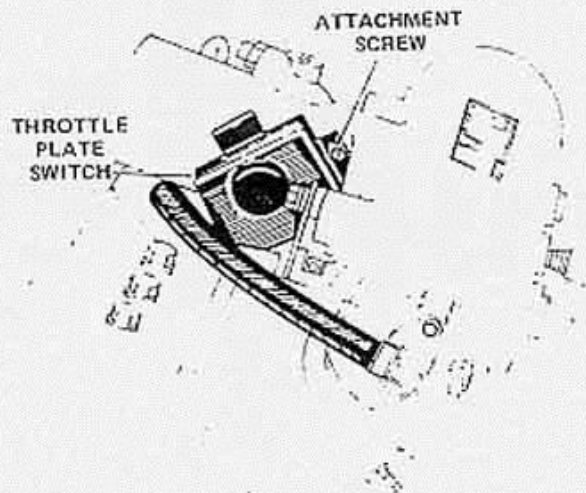

Lambda Sensor Indicator Reset

NOTE: Lambda sensor indicator comes on at 30,000 to indicate replacement of the sensor. To turn indicator off, the switch unit must be reset.

- Remove wire screening cap screw. Remove screw.
- Insert small screwdriver through housing and press on switch contact. Contact will reset to high point on wheel.
- Install cap screw. Secure screw with wire.

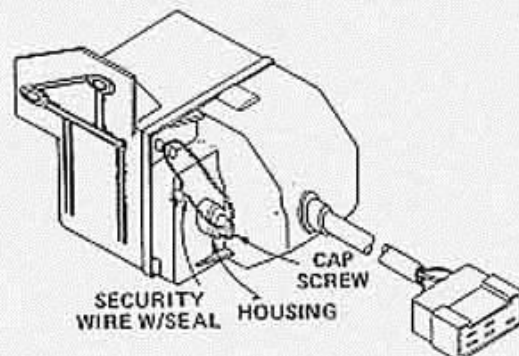

MAINTENANCE

1500 CC ENGINE

Page 59

Lambda Sensor Replacement

NOTE: The Lambda Sensor must be replaced every 30,000 miles.

- Allow exhaust system to cool.
- Disconnect cable from sensor.
- Remove sensor from exhaust manifold.

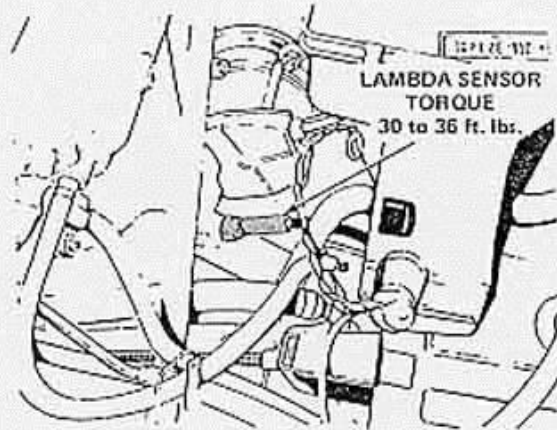

- Coat threads of new sensor with anti-seize, anti-rust grease.

CAUTION: Do not allow grease to get on sensor surface. This will contaminate sensor and require replacing sensor.

- Thread sensor into exhaust manifold. Torque sensor to 30 to 36 lb. ft.
- Connect cable to sensor. Check CO.

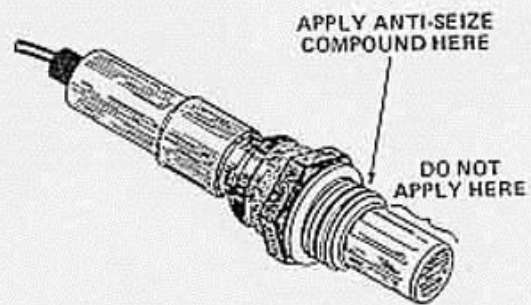

Fuel Injectors Removal and Installation

- Provide container to catch any fuel. Use care to prevent dirt from entering system.

CAUTION: Relieve fuel system pressure before disconnecting fuel lines.

- Relieve fuel system pressure as follows:
 - Remove fuel tank cap.
 - Disconnect vacuum hose from fuel pressure regulator.
 - Using a hand vacuum pump, apply 25 in. Hg to the pressure regulator.

NOTE: Fuel pressure will be released into the fuel tank through the fuel return hose.

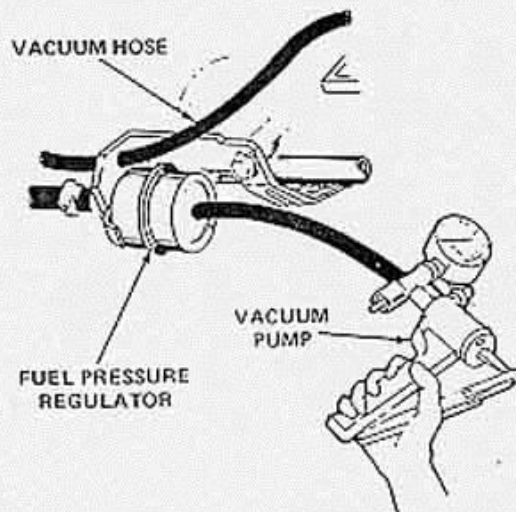

- Disconnect the following:

NOTE: Place rag under fuel hoses to catch fuel.

- Fuel supply hose from tube. Use a 12 mm wrench to hold fuel tube and a 17 mm wrench to turn fuel hose connection.
- Fuel return hose from pressure regulator.
- Vacuum hose from pressure regulator.
- Fuel hose from cold start valve.
- Main air supply hose from throttle housing.

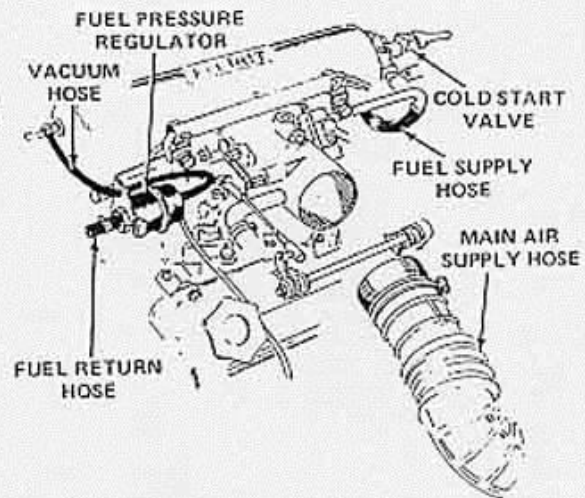

On Strada models,

- Disconnect electrical connectors from fuel injectors and throttle plate switch. Remove tube for wire harness from clamps on intake manifold. Move harness out of way.
- Disconnect the following:
 - Crankcase evaporative hose from throttle plate housing.
 - Auxiliary air regulator hose from intake manifold.
 - Crankcase evaporative bypass hose from intake manifold.
 - Accelerator cable from linkage.
- Remove two 10 mm bolts holding fuel manifold and harness clamps to intake manifold. Remove clamps. Remove washers from either side of bushings in fuel manifold brackets.

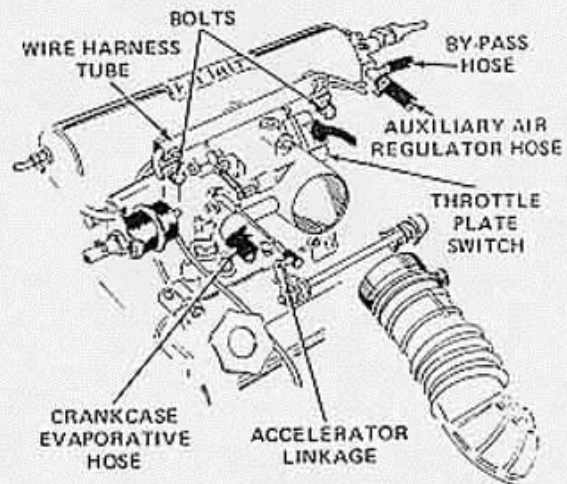

On X 1/9 models,

- Disconnect the following:
 - Accelerator cable from linkage.
 - Electrical connectors for throttle plate switch and cold start valve.
 - Auxiliary air regulator hose from intake manifold.
 - Crankcase evaporative bypass hose from intake manifold.

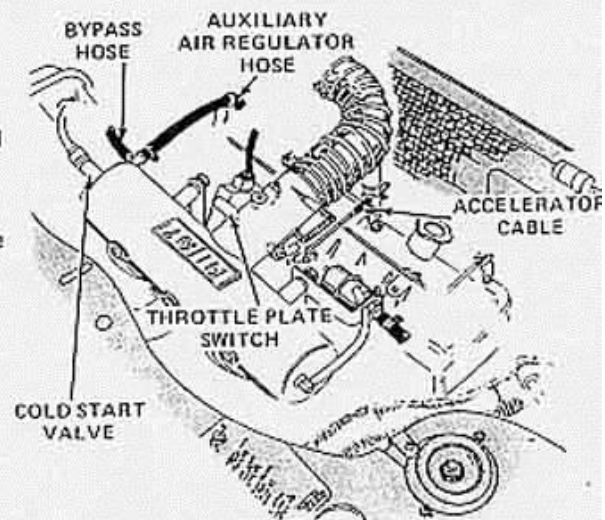

MAINTENANCE

1500 CC ENGINE

On X 1/9 models,

- Remove two 13 mm nuts and washers holding intake manifold cooling air duct to studs on manifold.
- Disconnect cooling air hose from duct. Remove duct.

On Strada and X 1/9 models,

- Remove four 13 mm nuts and eight washers holding air intake to manifold.
- Carefully lift air intake off studs in manifold. Tilt air intake backwards.

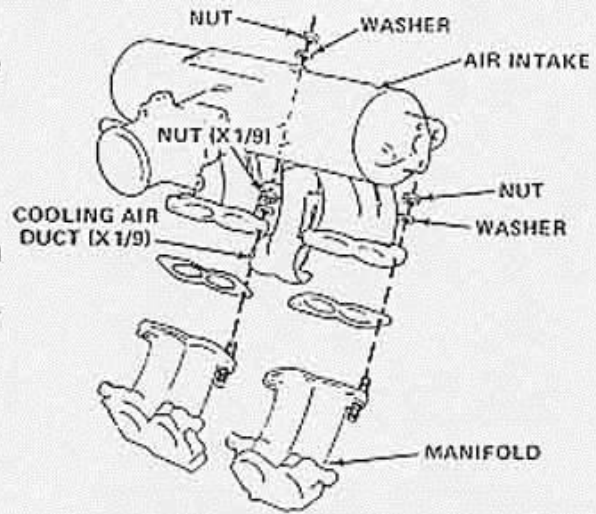

On X 1/9 disconnect electrical connectors from injectors.

- Using 4 mm allen wrench, remove two bolts and washers holding fuel injectors in intake manifold.
- Remove fuel injectors and adapters from manifold. Be careful of bushings and "O" rings on injectors and adapters.
- Remove fuel manifold.

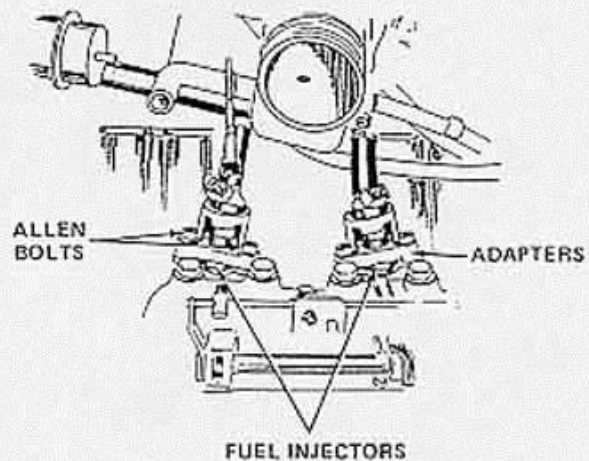

- Remove small and large rubber bushings and retainers from injectors.
- Remove "O" ring from adapter.
- Inspect bushings and "O" rings for cracks and damage.

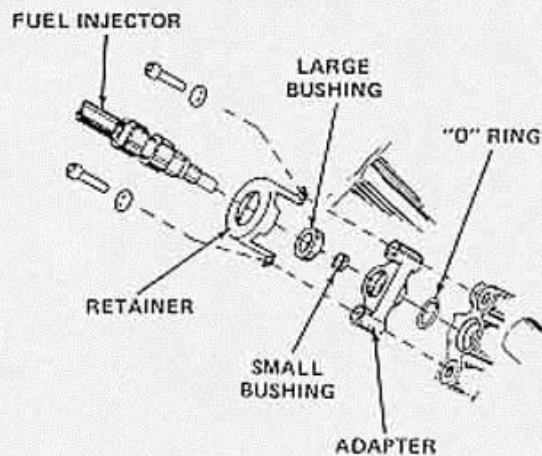

NOTE: When replacing a defective injector, replace injector and hose.

- To replace injector, pull hose off fuel manifold. Use a twisting, rocking motion while pulling on hose.
- To replace a damaged hose from a good injector, cut the hose at both ends and remove it.
- When installing the new hose or injector, place collar over shoulder of injector and manifold.
- Push hose on injector and manifold until hose end is inside collar and collar is tight against shoulder.

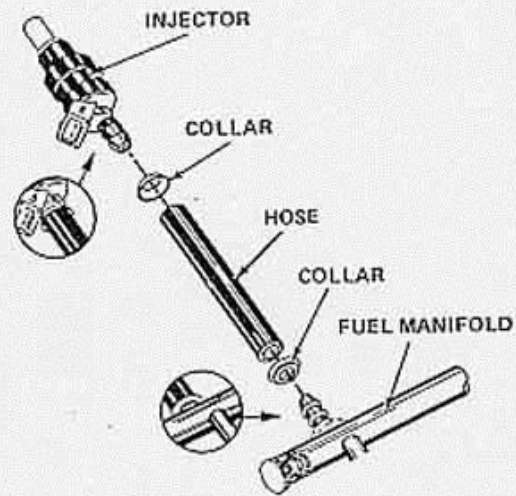

- Place retainers on injectors. Slide large bushings on injectors until it is seated in groove in injector. Place small bushing on tip of injectors.
- Place "O" rings on adaptors.
- Place adaptors in intake manifold. Install injectors in adaptors and secure them with two allen bolts and washers for each injector.

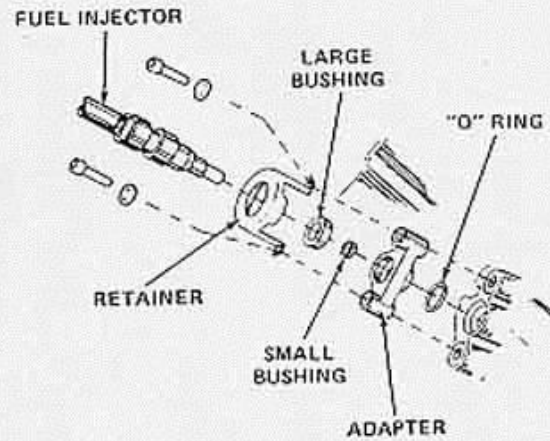

- Reinstall air intake to manifold with four nuts and eight washers.
- On X 1/9 models, install cooling air duct on manifold studs. Connect air hose to duct.

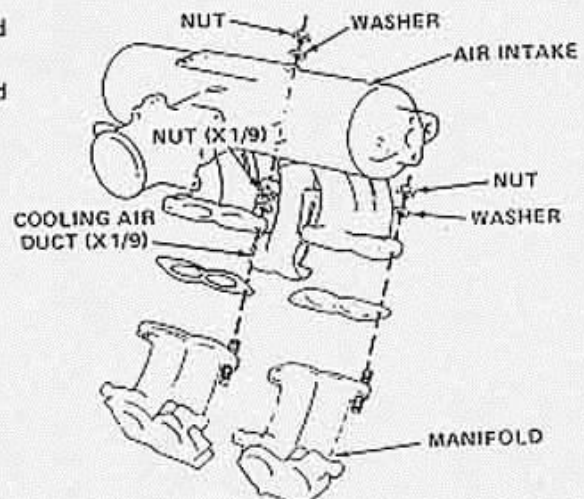

MAINTENANCE

1500 CC ENGINE

Page 63

- Reinstall fuel manifold, wire harness clamps (Strada), air hoses, accelerator linkage, vacuum hoses, electrical connectors, and fuel lines in reverse order.
- Make sure:
 - all components are clean
 - retainer bolts are tight
 - all lines are tight
- Check all fuel and air connections for leaks.

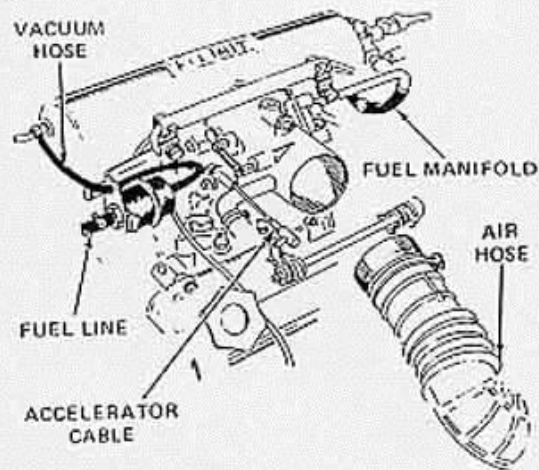

Fuel Pressure Regulator Removal and Installation

- Relieve fuel system pressure as directed under Fuel Injectors Removal and Installation.
- Provide a container to catch any fuel. Use care to prevent dirt from entering system.
- Disconnect vacuum and fuel return hoses from pressure regulator.
- Disconnect fuel manifold connection from pressure regulator.
- Remove 24 mm nut holding regulator to fuel manifold. Remove regulator.
- Reinstall in reverse order. Check fuel connections for leaks.

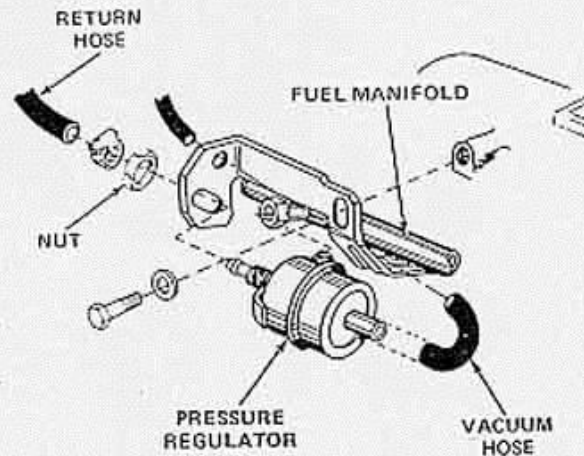

Cold Start Valve Removal and Installation

- Relieve fuel system pressure as directed under Fuel Injectors Removal and Installation.
- Provide a container to catch any fuel. Use care to prevent dirt from entering system.
- Disconnect electrical connector from cold start valve.
- Remove clamp holding fuel line on valve. Pull fuel hose off valve.

CAUTION: Use care in pulling fuel hose off valve. Valve body is plastic.

- Using 5 mm allen wrench, remove two screws holding valve in intake manifold. Remove valve.
- Reinstall in reverse order, making sure fuel hose is installed completely on valve and hose clamp is tight.
- Check fuel connection for leaks.

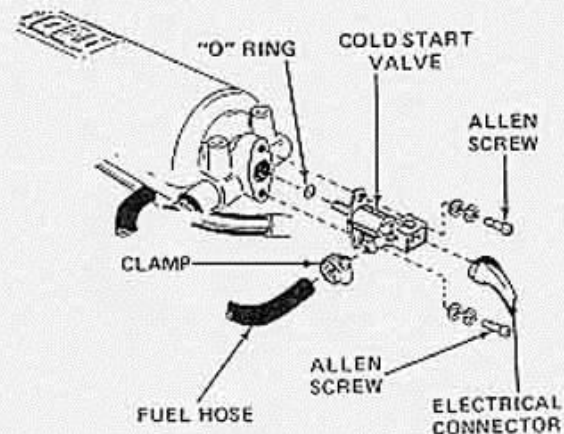

Air Flow Sensor Removal and Installation

- Disconnect air hoses from both sides of air flow sensor.
- Disconnect electrical connector from sensor.
- Remove 10 mm bolt and lockwasher holding mounting clamp to bracket. Remove clamp and spacer.
- Remove two 10 mm bolts, lockwashers, washers and bushings holding air flow sensor to bracket. Be careful not to drop washers on either side of rubber bushing under front side of sensor.
- Reinstall in reverse order, making sure rubber bushing is installed under sensor and air hose connections are tight.

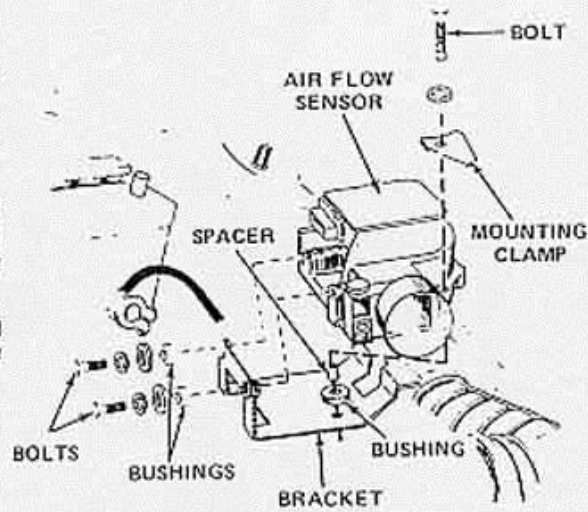

Auxiliary Air Regulator Removal and Installation

- Disconnect regulator air hose from intake manifold near cold start valve.
- Disconnect regulator air hose and charcoal trap hose from fitting in bottom of main air supply hose.
- Disconnect main air hose from air flow sensor.
- Disconnect electrical connector from regulator.
- Using 5 mm allen wrench, remove two bolts and washers holding regulator to cylinder block. Remove regulator and disconnect hoses.
- Reinstall in reverse order making sure air hose connections are tight and that clip is installed under clamps on regulator.

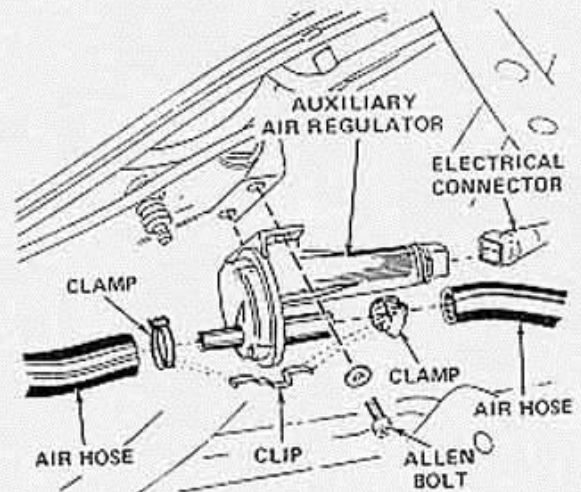

Throttle Plate Switch Removal and Installation

- Disconnect electrical connector.
- Remove two screws and washers holding switch to throttle housing.
- Remove switch by slowly pulling switch toward you.
- Reinstall in reverse order making sure switch is properly aligned with throttle shaft.
- Adjust throttle plate switch.

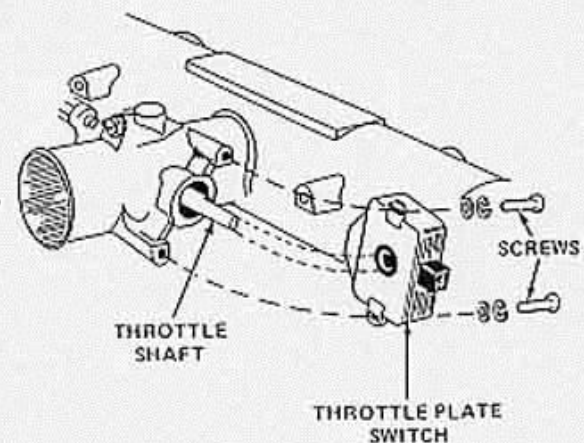

MAINTENANCE

2000 CC ENGINE

Page 65

Air Cleaner Filter Replacement

NOTE: The air filter element should be changed every 30,000 miles. If vehicle is frequently driven in heavy traffic or sandy or dusty areas, it is recommended to replace filter every 15,000 miles.

- Using a screwdriver, release the four catches.
- Lift the cover off and remove the filter.
- Install new filter and replace cover.
- Secure catches by pressing on curved section.

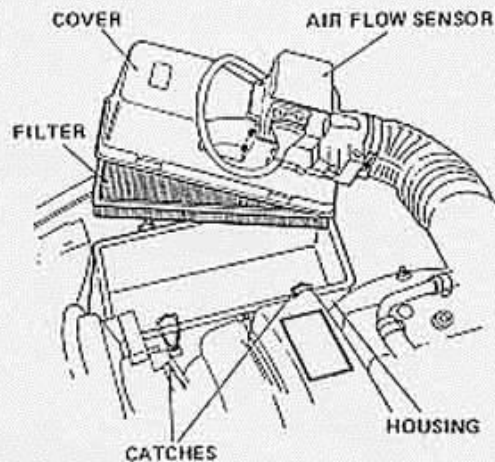

Idle Speed Adjustment

NOTE: Engine must be at normal operating temperature and the cooling fan off when adjusting idle speed.

- Connect tachometer. Run engine until it reaches normal operating temperature.
- On cars with automatic transmission, apply hand brake and place gearshift lever in "D".
- Adjust idle speed adjustment screw to obtain:
 - Manual Transmission 800 to 900 RPM
 - Automatic Transmission 700 to 800 RPM
- If idle speed cannot be set to proper speed or if throttle linkage or intake manifold was replaced, adjust accelerator linkage stop screw as directed below.

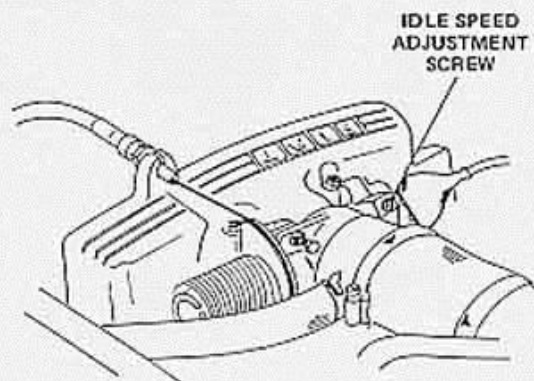

Accelerator Linkage Stop Screw Adjustment

NOTE: Perform this adjustment if idle speed cannot be set low enough or if throttle linkage or intake manifold was replaced.

- Connect tachometer. Run engine until it reaches normal operating temperature.

NOTE: Engine cooling fan must be off during this adjustment.

- On cars with automatic transmission, apply hand brake and place gearshift lever in "D".
- Turn idle speed adjustment screw in all the way.
- Adjust stop screw to obtain:
 - Manual Transmission 700 to 800 RPM
 - Automatic Transmission 600 to 700 RPM
- Hold stop screw and tighten the locknut.
- Adjust idle speed adjustment screw.

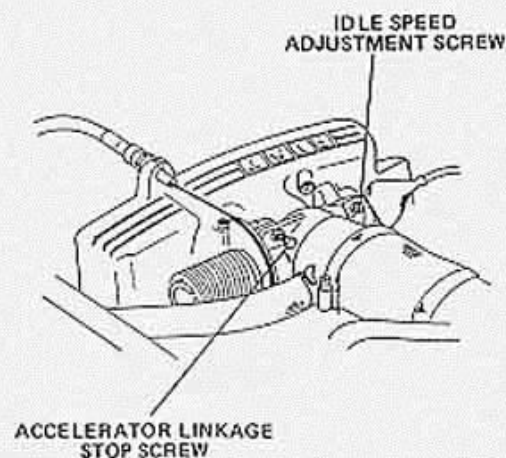

Idle CO Adjustment

NOTE: CO is set at the factory and no further adjustment is necessary unless a fuel injection component is replaced.

- Install the adapter kit on your CO Analyzer.

NOTE: The adapter kit contains instructions for installing the kit on your Analyzer.

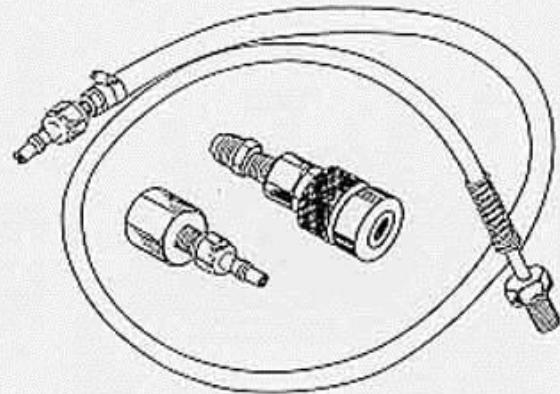

- Unscrew plug on pickup pipe or fitting near catalytic converter. Install the adapter nipple in the pickup. Connect hose from CO analyzer to nipple.
- Make sure there is no air leaking into the intake air system.
- Make sure idle speed is set correctly.

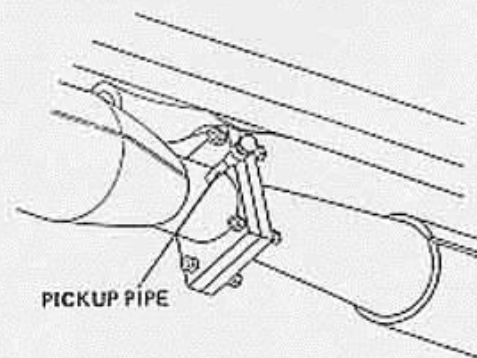

- Turn analyzer on and set it according to manufacturers' instructions.
- Disconnect wire from Lambda sensor. Make sure neither wire can ground out.
- Run engine until normal operating temperature is reached.

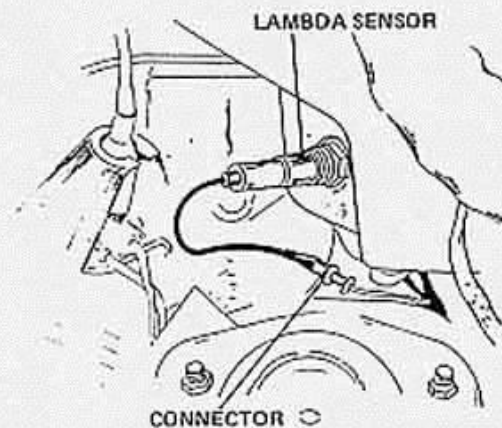

MAINTENANCE

2000 CC ENGINE

Page 67

- Remove aluminum plug from air flow sensor.
- Turn CO adjustment screw to set CO to $0.7\% \pm 0.2\%$.
 - clockwise – increase CO
 - counterclockwise – decrease CO
- Ground harness wire for Lambda sensor and check reading. CO reading should be at least 1.5%.
- Connect wire to Lambda sensor and check reading. CO reading must be between 0.3 and 0.6%.

WARNING: In next set, be very careful in removing nipple and installing plug. Exhaust pipe could be very hot.

- If reading is correct, remove analyzer nipple and install plug in pickup.
- Install replacement aluminum plug in air flow sensor.

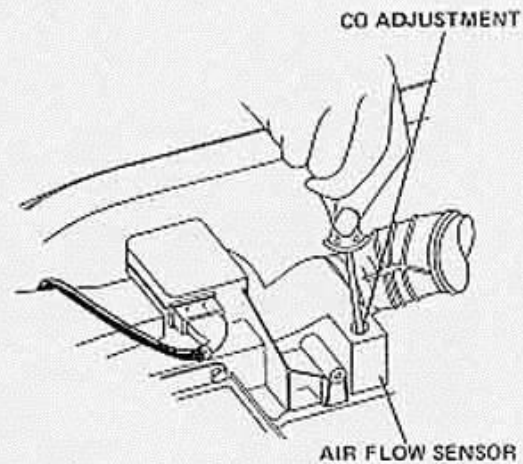

Accelerator and Kick-Down Cable Adjustment

- Make sure engine idle speed is set correctly.

Accelerator Cable

- Check for cable slack at the cable housing support on the intake manifold.
- Pull back lightly on the cable housing until just prior to moving throttle lever. Check for approximate clearance of 1 mm between adjustment nuts and support.
- If necessary, adjust nuts to obtain clearance.

Kick-Down Cable

- Depress accelerator cable until throttle lever contacts the maximum opening stop. Check that kick-down cable starts to pull at this point.
- Full depress accelerator. Check that kick-down cable extends 9 to 11 mm.
- If necessary, adjust nuts on housing to obtain correct extension of cable.

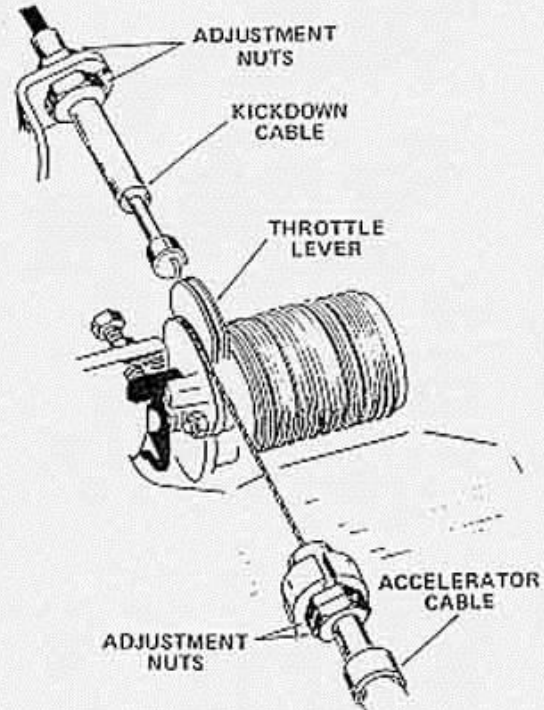

Throttle Plate Switch Adjustment

- Make sure idle speed is correct.
- Disconnect connector from throttle plate switch.
- Connect an ohmmeter between terminals 2 and 18 of the switch.

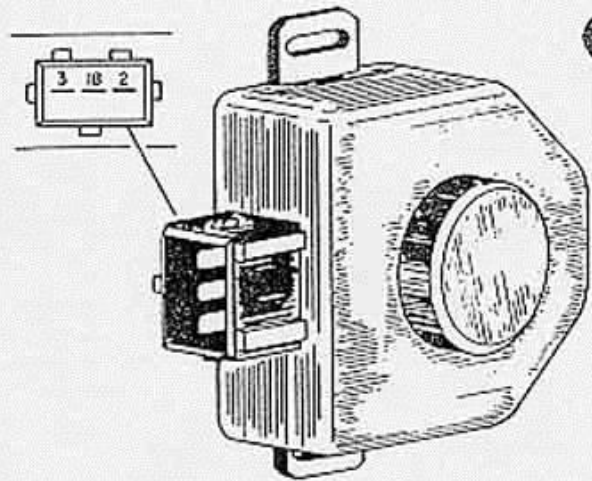

- Loosen two screws holding throttle plate switch.
- With engine off, rotate switch clockwise until ohmmeter indicates closed circuit.
- At the exact point ohmmeter indicates closed circuit, tighten the two screws holding the switch.
- Check the adjustment.

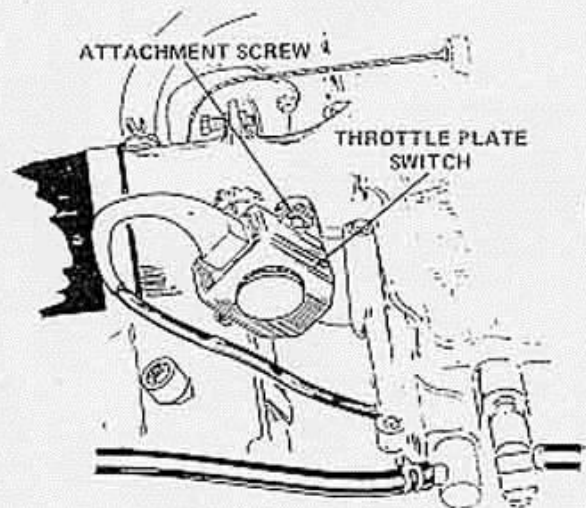

Lambda Sensor Indicator Reset

NOTE: Lambda sensor indicator comes on at 30,000 to indicate replacement of the sensor. To turn indicator off, the switch unit must be reset.

- Remove wire screening cap screw. Remove screw.
- Insert small screwdriver through housing and press on switch contact. Contact will reset to high point on wheel.
- Install cap screw. Secure screw with wire.

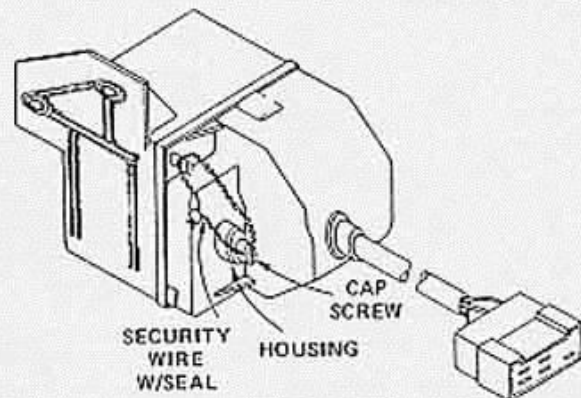

Lambda Sensor Replacement

NOTE: The Lambda Sensor must be replaced every 30,000 miles.

- Allow exhaust system to cool.
- Disconnect cable from sensor.
- Remove sensor from exhaust manifold.

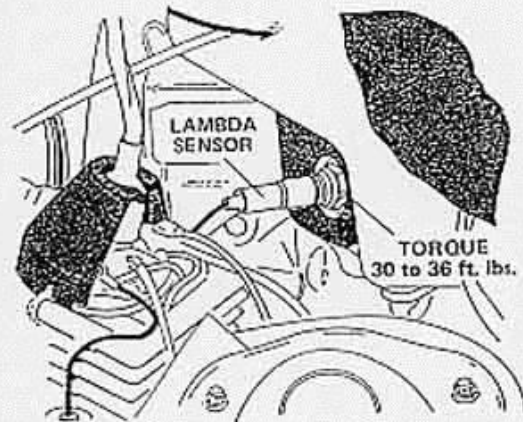

- Coat threads of new sensor with anti-seize, anti-rust grease.

CAUTION: Do not allow grease to get on sensor surface. This will contaminate sensor and require replacing sensor.

- Thread sensor into exhaust manifold. Torque sensor to 30 to 36 lb. ft.
- Connect cable to sensor. Check CO.

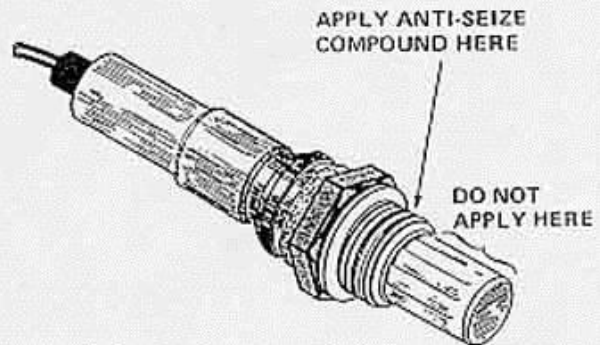

Fuel Injectors Removal and Installation

- Provide container to catch any fuel. Use care to prevent dirt from entering system.

CAUTION: Relieve fuel system pressure before disconnecting fuel lines.

- Relieve fuel system pressure as follows:
 - Remove fuel tank cap.
 - Disconnect vacuum hose from fuel pressure regulator.
 - Using a hand vacuum pump, apply 25 in. Hg to the pressure regulator.

NOTE: Fuel pressure will be released into the fuel tank through the fuel return hose.

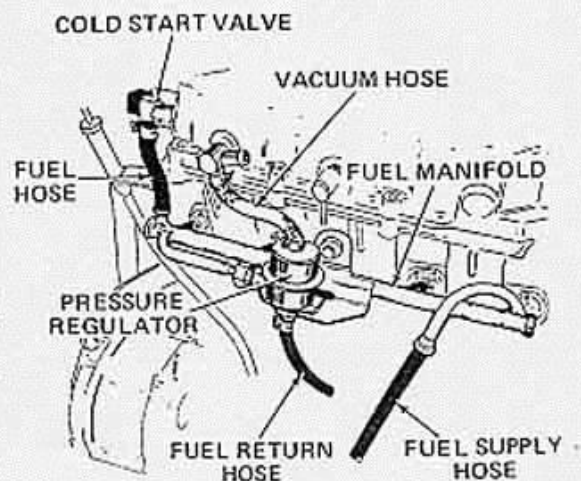

- Disconnect the following
 - Wire harness from injectors.

NOTE: Place rag under fuel hoses to catch fuel.

- Fuel supply hose from pipe. Use a 12 mm wrench to hold fuel line and a 17 mm wrench to turn fuel hose connection.
- Fuel return hose from pressure regulator.
- Vacuum hose from pressure regulator.
- Fuel hose for cold start valve from cold start valve.

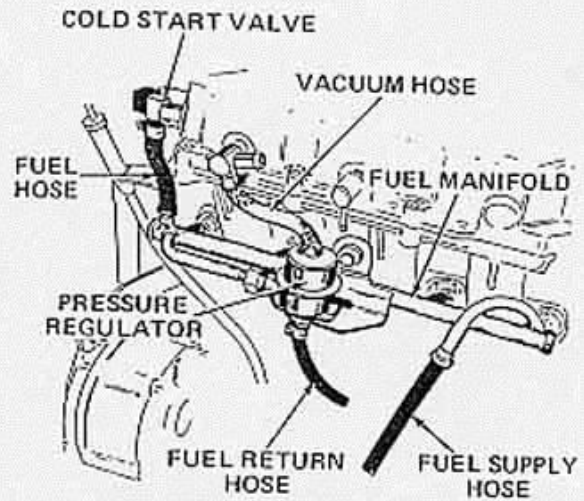

- Remove 10 mm bolt holding fuel manifold to intake manifold.
- Remove four 10 mm nuts and washers holding injector retainers to intake manifold.
- Remove fuel manifold complete with injectors and pressure regulator. Be careful of rubber bushings in intake manifold. They may fall out.
- Remove the four small and four large rubber bushings, and retainers from injectors. Inspect bushings for cracks and damage.

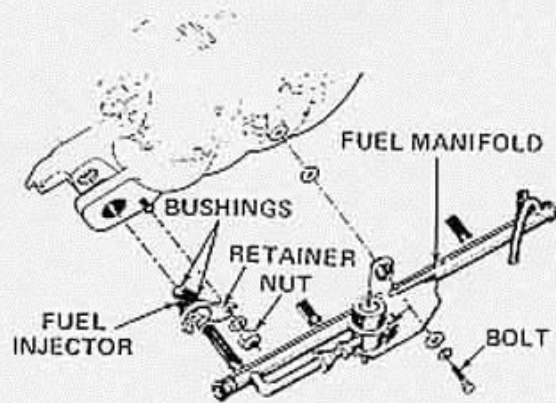

NOTE: When replacing a defective injector, replace injector and hose.

- To replace injector, pull hose off fuel manifold. Use a twisting, rocking motion while pulling on hose.
- To replace a damaged hose from a good injector, cut the hose at both ends and remove it.
- When installing the new hose or injector, place collar over shoulder of injector and manifold.
- Push hose on injector and manifold until hose end is inside collar and collar is tight against shoulder.

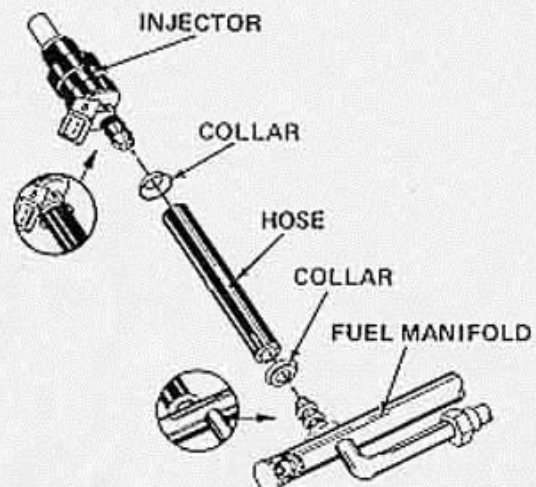

- Place retainers on injectors. Slide large bushing on injector until it is seated in groove in injector. Place small bushings on tip of injectors.
- Reinstall injectors and fuel manifold in reverse order, making sure:
 - all components are clean
 - rubber bushings are not damaged
 - rubber bushings are installed in intake manifold properly
 - injectors are installed in small bushings air-tight
 - retainers' holding nuts are tight
- Check all fuel connections for leaks.

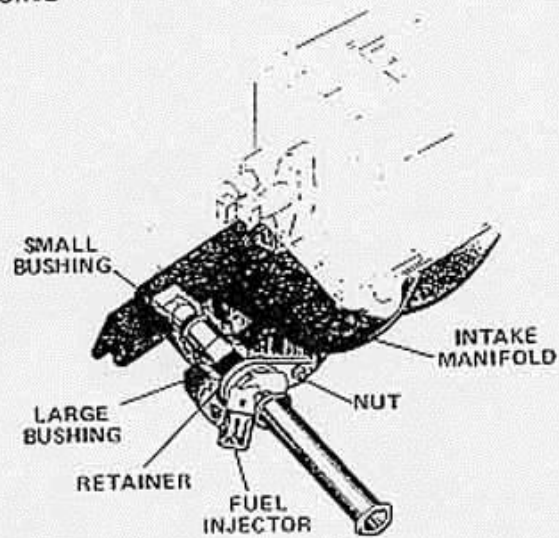

Fuel Pressure Regulator Removal and Installation

- Relieve fuel system pressure as directed under Fuel Injectors Removal and Installation.
- Provide a container to catch any fuel. Use care to prevent dirt from entering system.
- Disconnect vacuum and fuel return hoses from pressure regulator.
- Disconnect fuel manifold connection from pressure regulator.
- Remove 24 mm nut holding regulator to fuel manifold. Remove regulator.
- Reinstall in reverse order. Check fuel connections for leaks.

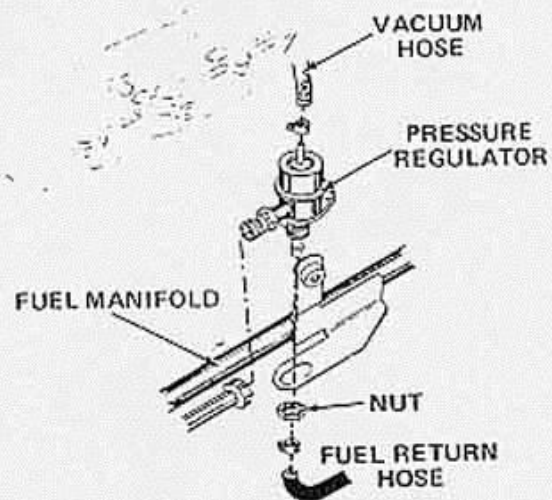

Cold Start Valve Removal and Installation

- Relieve fuel system pressure as directed under Fuel Injectors Removal and Installation.
- Provide a container to catch any fuel. Use care to prevent dirt from entering system.
- Disconnect electrical connector from cold start valve.
- Remove clamp holding fuel line on valve. Pull fuel hose off valve.

CAUTION: Use care in pulling fuel hose off valve. Valve body is plastic.

- Using 5 mm allen wrench, remove two screws holding valve in intake manifold. Remove valve.
- Reinstall in reverse order, making sure fuel hose is installed completely on valve and hose clamp is tight.
- Check fuel connection for leaks.

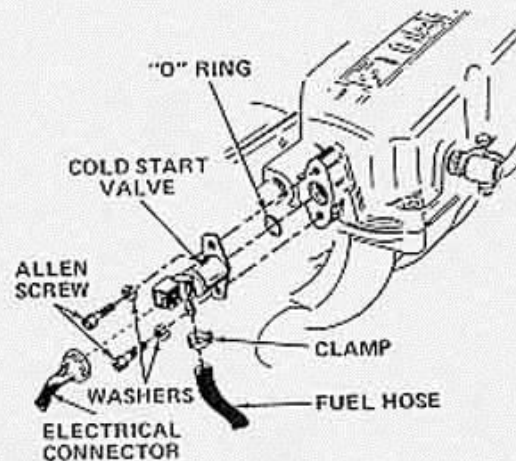

Air Flow Sensor Removal and Installation

- Disconnect electrical connector and air hose from air flow sensor.
- Remove air cleaner cover.
- Remove four 10 mm bolts and washers holding air flow sensor to air cleaner cover. Remove air flow sensor and gasket.
- Reinstall in reverse order, making sure air hose connection is tight.

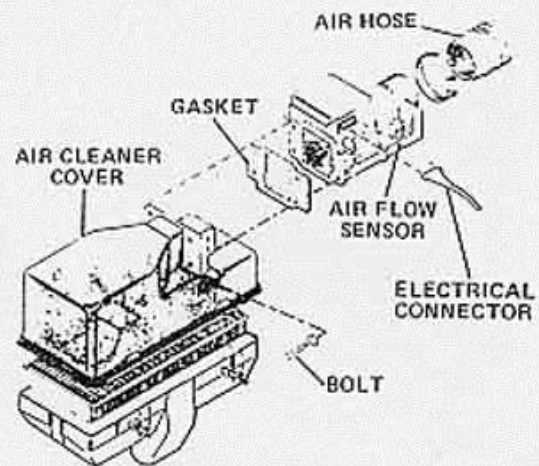

Auxiliary Air Regulator Removal and Installation

- Disconnect air hoses from both sides of regulator.
- Disconnect electrical connector from regulator.
- Remove two 10 mm bolts holding regulator to cylinder head.
- Reinstall in reverse order, making sure air hose connections are tight.

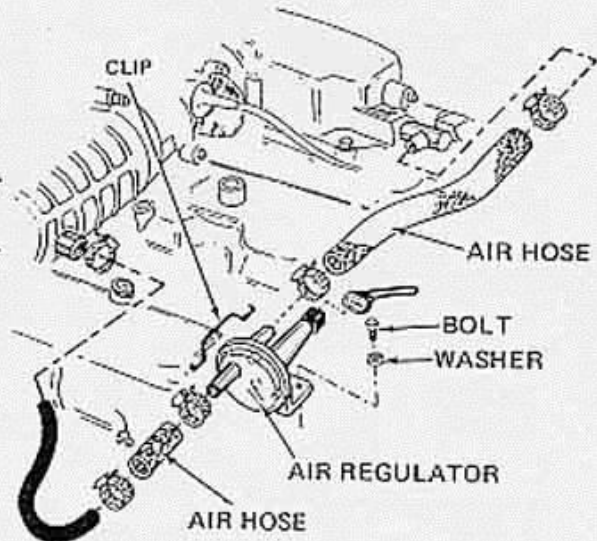

Throttle Plate Switch Removal and Installation

- Disconnect electrical connector.
- Remove two screws and washers holding switch to intake manifold.
- Remove switch by slowly pulling switch toward you.
- Reinstall in reverse order making sure switch is properly aligned with throttle shaft.
- Adjust throttle plate switch.

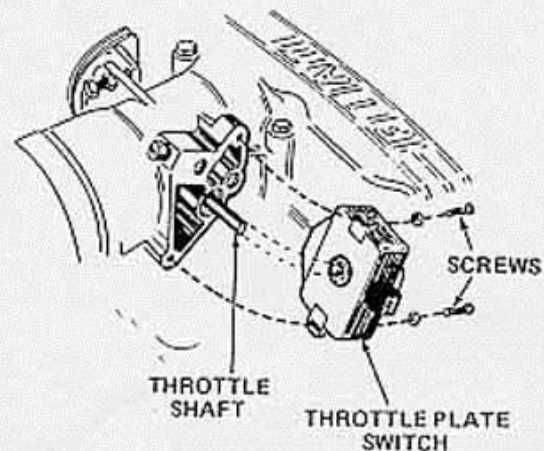

ELECTRICAL SYSTEM

Page 73/74

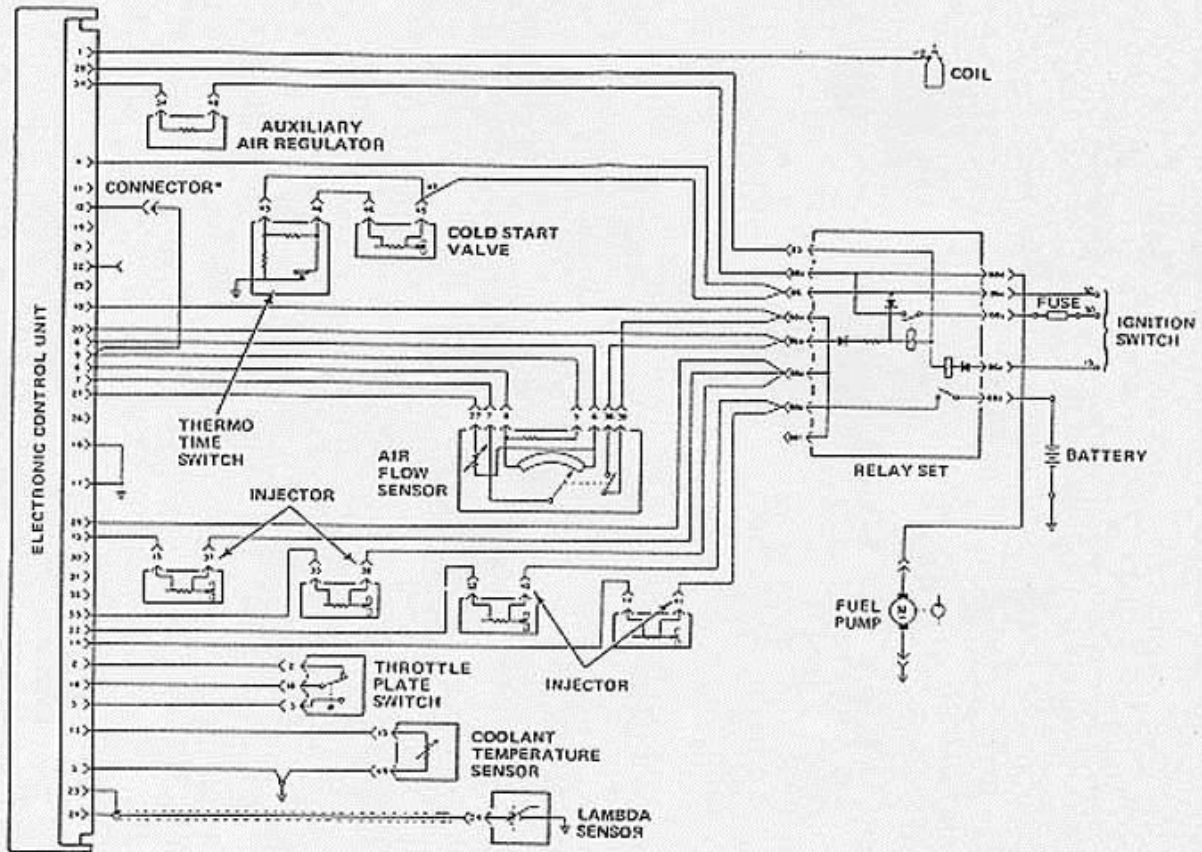

*Note: For high altitude correction beginning with 1982 model year.

Test specifications

Thermo time switch (35°/8s):

● Internal electrical resistance	Between "G" term. chassis	Between "W" term. chassis	Between "G" term. and "W"
Ambient temp. under +30°C	25...40 Ω	0Ω	25...40 Ω
working temp. over +40°C	50...80 Ω	100...160Ω	50...80 Ω

Cold start valve

- internal resistance 3.5...4.5 Ω
- leakage: max. allowance 1 drop/min.

Auxiliary air regulator

- internal resistance 25...75 Ω

Temperature sensor

● internal resistance	NTC I air	NTC II motor
Ambient temp. (+15°C...+30°C):	1.45...3.3 kΩ	1.30...3.6 kΩ
Working temp. (ca. +80°C):	280...360 Ω	250...390 Ω

A12

Test specifications

Different US-vehicles with L-Jetronic

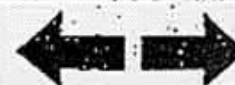

Test specifications

Solenoid injection valve (at +20°C):
• Internal resistance 2.0...3.0 Ω

Air pressure switch Only with vehicles with turbocharger
• Resistance value
at atmospheric pressure ∞ Ω
at ca.1000...1500 mbar over-
pressure 0 Ω

Air flow meter

Date of Manufacture

• Resistance value
Contac on air flow
meter

to 6/80

from 6/80

term. 6 - term. 9	200 ... 400 Ω	400 ... 800 Ω
term. 6 - term. 8	130 ... 260 Ω	260 ... 520 Ω
term. 8 - term. 9	70 ... 140 Ω	140 ... 280 Ω
term. 6 - term. 7	40 ... 300 Ω*	80 ... 600 Ω*
term. 7 - term. 8	100 ... 500 Ω*	200 ... 1000 Ω*

* The reading of the meter changes with the opening of the sensor flap.

Pressure sensor (Only on vehicles with altitude sensor)

300 m high (977 mbar): 2.0... 4.0 V
4000 m high (616 mbar): 8.0...12.0 V

• Resistance between term. 2 (-)
and term. 3 (+): 2.3...2.8 kΩ

A13

Test specifications

Different US-vehicles with L-Jetronic

